



# **Epson<sup>®</sup> SureColor<sup>®</sup> F6200 User's Guide**



---

# Contents

<b>Epson SureColor F6200 User's Guide .....</b>	<b>7</b>
<b>Introduction to Your Printer.....</b>	<b>8</b>
Notations Used in the Documentation .....	8
Printer Part Locations .....	8
Product Parts - Front and Side .....	9
Control Panel Parts .....	12
Consumables and Replacement Parts .....	15
Printer Usage Guidelines .....	16
Using Your Printer .....	16
Handling Ink Packs and Ink Tanks.....	17
Handling Media.....	17
Storing Your Printer .....	18
<b>Media Handling.....</b>	<b>20</b>
Loading Media.....	20
Viewing and Changing Media Settings.....	27
Saving Sets of Media Settings.....	28
Printable Area and Media Size Checking.....	29
Adjusting the Media Feed.....	33
Adjusting the Media Feed During Printing .....	34
Cutting Media .....	35
Removing Media .....	36
<b>Using the Control Panel Menus.....</b>	<b>39</b>
Accessing the Printer's Menus .....	39
Paper Menu Settings.....	39
Maintenance Menu Settings.....	41
Setup Menu Settings .....	43
<b>Maintenance.....</b>	<b>48</b>
Maintenance Precautions.....	48
Cleaning the Product.....	49
Stirring High Density Black Ink .....	51

Replacing the Ink and Chip Unit .....	54
About Ink and Chip Unit Replacement.....	54
Ink and Chip Unit Precautions .....	55
Replacing the Chip Unit and Refilling Ink.....	56
Print Head Maintenance .....	67
Checking for Clogged Print Head Nozzles.....	68
Cleaning the Print Head.....	69
Aligning the Print Head .....	70
Performing Head Maintenance .....	71
Replacing the Waste Ink Bottle .....	75
Replacing the Cutter.....	78
<b>Moving or Transporting the Product .....</b>	<b>82</b>
Prepare to Move the Product.....	82
Setting Up the Product After Moving .....	82
<b>Solving Problems .....</b>	<b>84</b>
Product Status Messages .....	84
Solving Printer Problems.....	87
Printer Does Not Turn On .....	87
Product Turns Off Automatically .....	87
LCD Screen Shuts Off .....	88
Forgot the Administrator Password .....	88
Red Light Shines Inside the Printer .....	88
Solving Printing Problems .....	88
Nothing Prints .....	88
Cannot Print Over a Network.....	89
Print Head Moves But Nothing Prints .....	89
Removing Jammed Media.....	90
Media Does Not Feed or Eject Correctly.....	91
Media Does Not Cut Cleanly .....	91
Solving Print Quality Problems.....	91
Nozzle Check Pattern Prints Incorrectly .....	92
Overall Print Quality Is Poor .....	92
Printed Media is Stained or Marred .....	93

Image is not Positioned Correctly on the Media.....	93
Where to Get Help.....	94
<b>Technical Specifications .....</b>	<b>95</b>
Windows System Requirements .....	95
Printing Specifications .....	96
Electrical Specifications .....	96
Environmental Specifications .....	97
Dimension Specifications .....	97
Interface Specifications .....	97
Ink Pack Specifications .....	98
Paper Specifications .....	98
Safety and Approvals Specifications .....	99
<b>Notices .....</b>	<b>100</b>
Important Safety Instructions.....	100
General Product Safety Instructions .....	100
Ink Pack Safety Instructions .....	102
FCC Compliance Statement.....	102
Software License Terms.....	103
Trademarks .....	110
Copyright Notice.....	111
A Note Concerning Responsible Use of Copyrighted Materials.....	111
Copyright Attribution .....	112



---

# Epson SureColor F6200 User's Guide

Welcome to the Epson SureColor F6200 *User's Guide*.

---

# Introduction to Your Printer

Refer to these sections to learn more about your printer and this manual.

[Notations Used in the Documentation](#)

[Printer Part Locations](#)

[Consumables and Replacement Parts](#)

[Printer Usage Guidelines](#)

## Notations Used in the Documentation

Follow the guidelines in these notations as you read your documentation:

- **Warnings** must be followed carefully to avoid bodily injury.
- **Cautions** must be observed to avoid damage to your equipment.
- **Notes** contain important information about your printer.
- **Tips** contain additional printing information.

**Parent topic:** [Introduction to Your Printer](#)

## Printer Part Locations

Check the printer part illustrations to learn about the parts on your printer.

[Product Parts - Front and Side](#)

[Control Panel Parts](#)

**Parent topic:** [Introduction to Your Printer](#)



## Product Parts - Front and Side

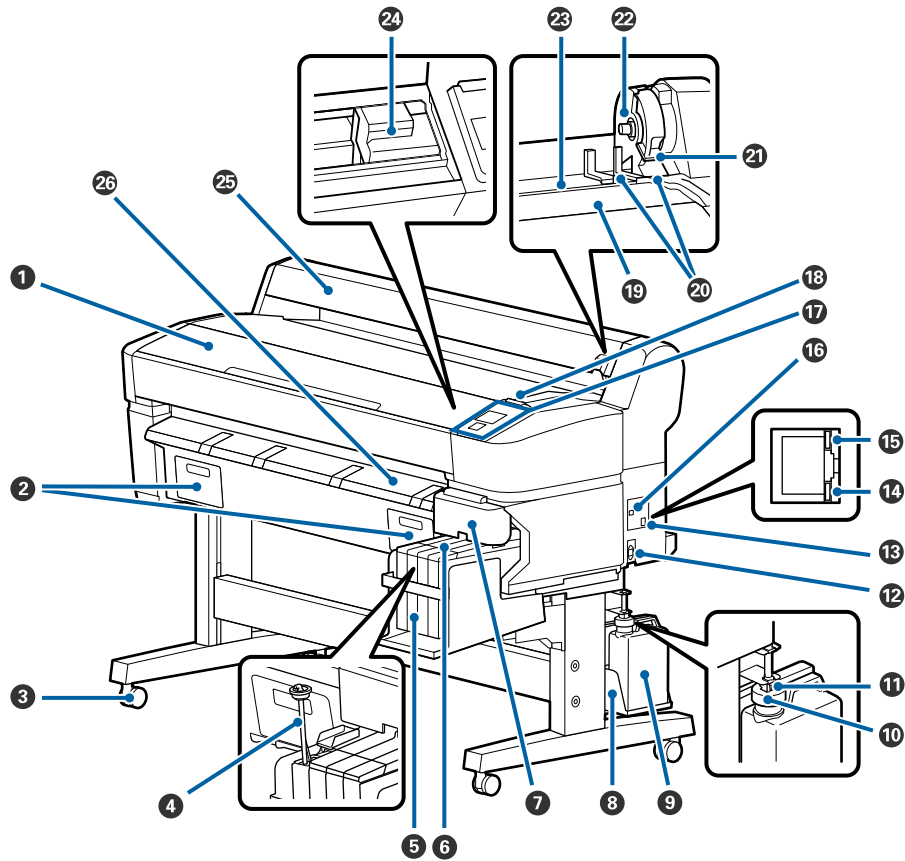

- 1 Printer cover
- 2 Maintenance box covers
- 3 Casters
- 4 Stirring stick
- 5 Ink tank
- 6 Slider (chip holder)

- 7 Side cover
- 8 Waste ink bottle holder
- 9 Waste ink bottle
- 10 Ink splash guard
- 11 Waste ink tube
- 12 AC inlet
- 13 LAN port
- 14 Data light
- 15 Status light
- 16 USB port
- 17 Control panel
- 18 Alert light
- 19 Roll rest
- 20 Adapter guides
- 21 Roll lock lever
- 22 Adapter holder
- 23 Paper slot
- 24 Print head
- 25 Roll paper cover
- 26 Paper eject guide

### Slider (Chip Holder) Parts

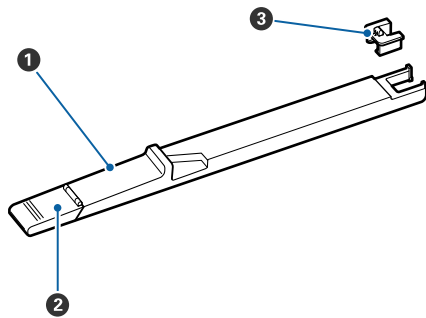

- 1 Slider
- 2 Ink inlet cover
- 3 Chip unit

### Roll Paper Adapter

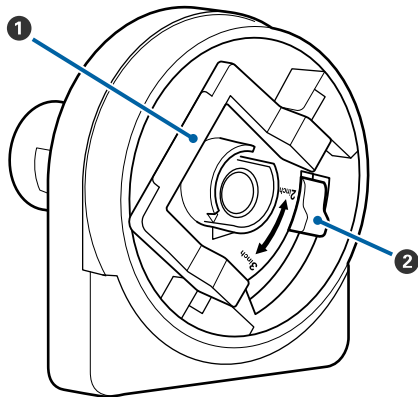



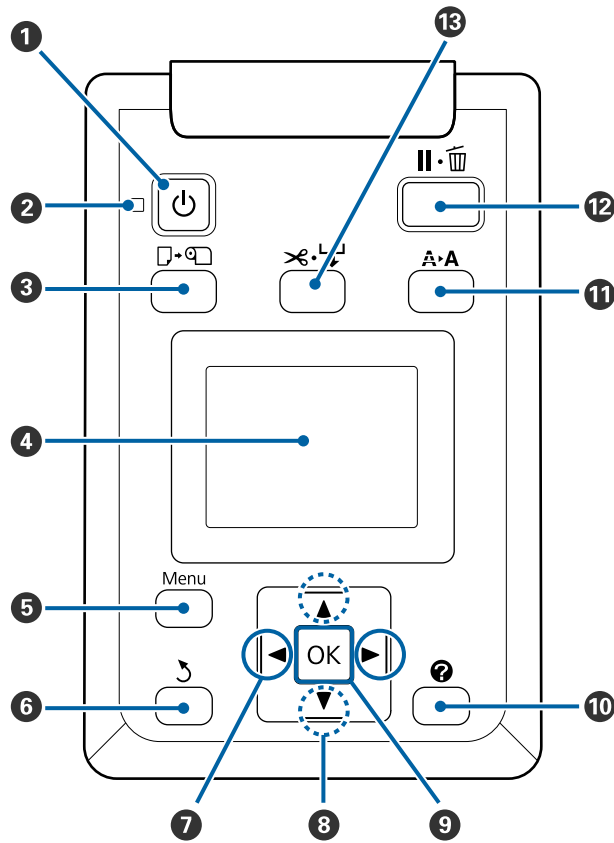

- 1 Adapter lock lever
- 2 Size lever

Parent topic: [Printer Part Locations](#)

## Control Panel Parts





- 1 The ⏻ power button
- 2 The ⏻ power light
- 3 The 📄 load/remove paper button
- 4 LCD screen
- 5 The **Menu** button
- 6 The ↶ back button
- 7 The left and right arrow buttons

- 8 The up and down arrow buttons
- 9 The **OK** button
- 10 The  ink tab info button
- 11 The  maintenance button
- 12 The  pause/cancel button
- 13 The  cut/feed media button

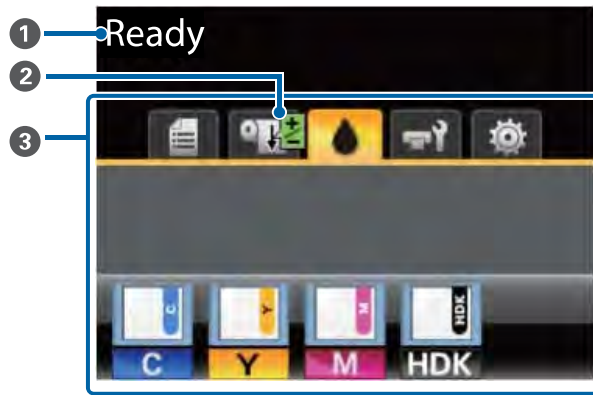
**LCD Screen Display**



1	Status messages
2	Feed adjustment information, if you have entered a value during printing
3	Information display area with the 5 tabs described in the next table

 Print status tab	Displays information about the print jobs in the print queue. Press the <b>OK</b> button to display the Print Job menu.
 Paper status tab	Displays information about the loaded paper, such as roll width and amount of paper remaining. Press the <b>OK</b> button to display the Paper menu.

Chip unit status tab

The chip unit status (1) changes from normal (left) to warning or error status (right) if necessary.

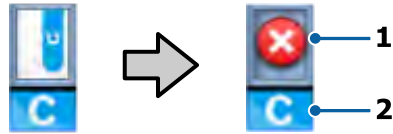

The ink color is shown below (2).

- HDK: High Density Black
- Y: Yellow
- M: Magenta
- C: Cyan



: Chip unit error; check the displayed message and clear the error









: Chip unit is incompatible, or the printer does not recognize it, or the slider is unlocked



: Check the displayed chip unit message



: When not flashing, check the ink level in the ink tank, then replace the chip unit and refill the ink, if necessary. When flashing, replace the chip unit.

 Waste ink bottle status tab	<p>The waste ink bottle status indicates the waste ink level and changes from normal (left) to warning or error status (right) if necessary. Press the <b>OK</b> button to display the Maintenance menu.</p> <div style="text-align: center;">   </div> <p style="text-align: center;">→</p> <div style="text-align: center;">  </div> <p>: Waste ink bottle is almost full; prepare a new waste ink bottle</p> <div style="text-align: center;">  </div> <p>: Waste ink bottle is full; replace the waste ink bottle</p>
 Setup tab	<p>Displays the product's IP address and menus for various settings. Press the <b>OK</b> button to display the Setup menu.</p>

Parent topic: [Printer Part Locations](#)

## Consumables and Replacement Parts

You can purchase genuine Epson ink packs, paper, and accessories from an Epson authorized reseller. To find the nearest reseller, call 800-GO-EPSON (800-463-7766).

**Caution:** Using ink from a non-genuine ink pack may result in a malfunction. Epson shall not be held responsible for any damages or problems with the product that may occur when using non-genuine ink packs.

Consumable	Part number
High-Density Black	T741X00
Cyan	T741200
Magenta	T741300
Yellow	T741400

Replacement part	Part number
Auto cutter spare blade	S902006
Roll adapter	C12C811391
Waste ink bottle	T724000
Head maintenance kit	S210042

**Parent topic:** [Introduction to Your Printer](#)

## Printer Usage Guidelines

Follow the guidelines in these sections as you use your printer, consumables, and print media.

[Using Your Printer](#)

[Handling Ink Packs and Ink Tanks](#)

[Handling Media](#)

[Storing Your Printer](#)

**Parent topic:** [Introduction to Your Printer](#)

## Using Your Printer

Follow these guidelines as you use your printer:

- Operate the printer only within the specified operating temperature and humidity range for your product and your media.
- Check to make sure you maintain the specified humidity range, especially in dry areas or air conditioned environments.
- Do not install the printer next to heat sources or directly in the path of exhaust from a ventilator or air conditioner. Failure to observe this precaution could result in the print head nozzles drying out and clogging.
- Make sure the product work space is kept free of dust or lint that could damage your product or clog the print head nozzles.
- Use the product in a sufficiently ventilated area.
- Perform maintenance operations according to usage frequency or at the recommended intervals. Failure to perform regular maintenance could reduce print quality or damage the print head.
- Do not bend or pull the waste ink tube. Otherwise ink may leak inside or outside the printer.
- Be sure that the waste ink bottle is installed whenever the printer is turned on.



- If an error occurs and the printer is turned off without first resolving the error, the print head may not be in the home position, which may cause the print head to dry out. In this case, turn on the power and wait until the carriage is in the home position.
- When the printer is on, do not disconnect the power cable or cut the power at the circuit breaker. The print head may not be in the home position. In this case, turn on the power and wait a while until the print head is in the home position.
- For consistent color, maintain a constant room temperature between 59 °F (15 °C) and 77 °F (25 °C).

**Note:** To keep the print head in the optimum operating condition, ink is used in maintenance operations such as head cleaning in addition to printing.

**Parent topic:** [Printer Usage Guidelines](#)

## Handling Ink Packs and Ink Tanks

Follow these guidelines as you handle the ink packs and ink tanks:

- Do not remove the ink tanks. Ink tanks are calibrated at installation and removing them can decrease their functionality.
- Do not place items on an ink tank or subject the ink tanks to strong impacts or the tank may detach. If an ink tank comes off, contact Epson support.
- Store ink packs at room temperature, out of direct sunlight.
- To ensure print quality, use all the ink in the ink pack before the date printed on the ink pack or within 25 days of refilling the ink tank, whichever is earlier.
- Allow ink packs that have been stored at low temperatures for an extended period of time to return to room temperature over a period of four hours before use.
- Refill the ink tank as soon as possible after opening an ink pack.
- When refilling an ink tank, use all of the ink in the ink pack at once.

**Parent topic:** [Printer Usage Guidelines](#)

## Handling Media

Follow these guidelines as you handle or store media:

- Read and follow the guidelines provided with each type of media.
- Do not fold the media or otherwise damage its printable surface.

- Do not touch the printable surface. This prevents oil from your hands from causing print quality problems.
- When handling media, hold it by both edges, preferably while wearing cotton gloves.
- Keep the media dry and avoid storage locations subject to direct sunlight, excessive heat, and high humidity.
- Retain the media packaging materials so you can use it to store unused media.
- After printing, do not touch, rub, or scratch the printed surface to avoid removing the ink.
- Dry printed media completely before folding or stacking it, or the printed surface may be damaged.
- Keep printed media out of direct sunlight.
- Display and store printed media as instructed in the media documentation.
- When you are not printing on media, remove it from the printer and place it in its original packaging to prevent deterioration.

Parent topic: [Printer Usage Guidelines](#)

## Storing Your Printer

Follow these guidelines if you need to store your printer for a long period:

- If the printer is not used for an extended period of time with the power off, clean the print head nozzles. Turn the printer on at least once every two weeks to automatically clean the print head and prevent the nozzles from clogging. If you do not turn on the printer for a long time, the printer may malfunction.
- If you will not use the printer for more than two weeks, maintenance must be performed by a service engineer before and after this period. Contact Epson support.
- Even if the printer is not turned on, ink that has accumulated in the waste ink tube may leak out. Make sure the waste ink bottle is installed even when the printer is not on.
- Remove any loaded media before storing the printer to prevent the pressure rollers from causing creases in the media, which may cause jams or damage to the print head.
- Make sure that the print head is in the home position before storing the printer. If it is left away from the home position for a long time, the print quality may decline.
- Close all the covers on the printer to prevent dust and debris from getting in. If the printer will be not be used for an extended period of time, protect it with an anti-static cloth or other cover. The print head nozzles can become clogged if fine dust gets on the print head, and you may not be able to print properly.
- Store the printer on a level surface; do not store it on angle, on its end, or upside down.

**Parent topic:** [Printer Usage Guidelines](#)

---

# Media Handling

See these sections to load and handle media on your product.

[Loading Media](#)

[Viewing and Changing Media Settings](#)

[Saving Sets of Media Settings](#)

[Printable Area and Media Size Checking](#)

[Adjusting the Media Feed](#)

[Cutting Media](#)

[Removing Media](#)

## Loading Media

Before loading media in your printer, review and follow the media handling guidelines for the best results.

**Caution:** Wait until just before printing to load media. This avoids creases in the media that may be caused by the pressure rollers. Creased, wavy, or curled media could cause it to jam inside the printer or contact the print head.

1. Press the  power button.
2. Open the roll paper cover.

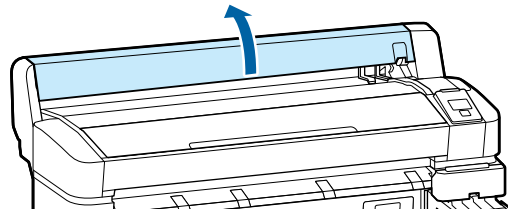

3. Lift up the adapter holder lock lever.

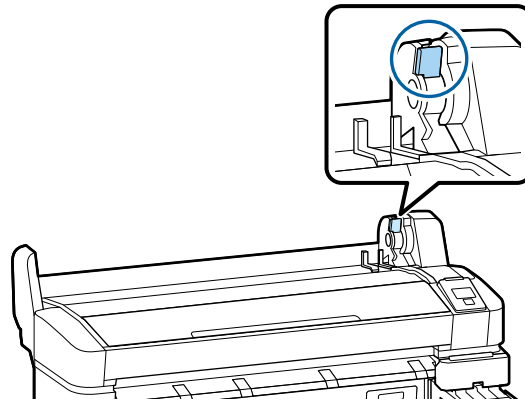

4. Place your media on the roll rest temporarily.

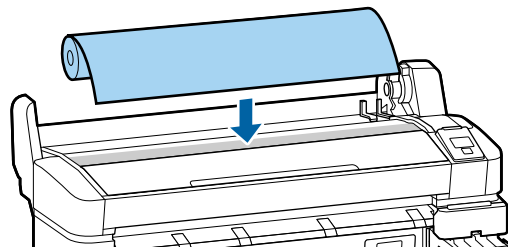

5. On the roll paper adapters, slide the size lever to the position for the size of the roll core on the media you are loading.

- **3-inch core**

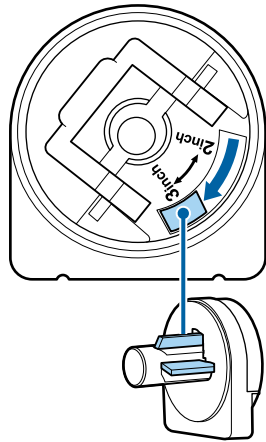

- **2-inch core**

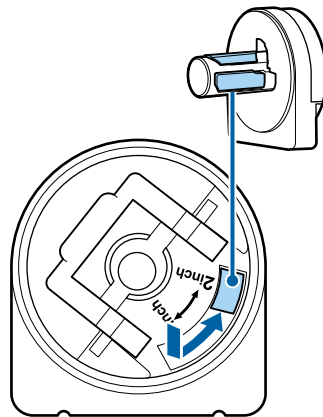

6. Lift up the lock levers on both roll paper adapters.

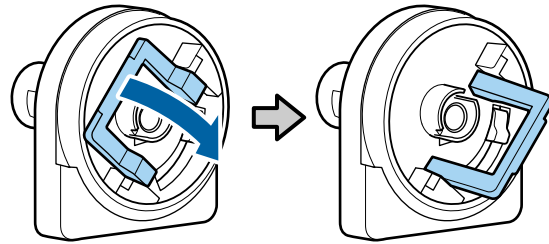

7. Attach the roll paper adapters to each end of your media roll and press them in until they are fully inserted.

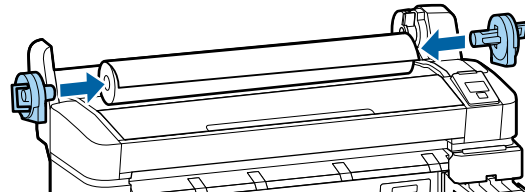

8. Lower the lock levers on both roll paper adapters.

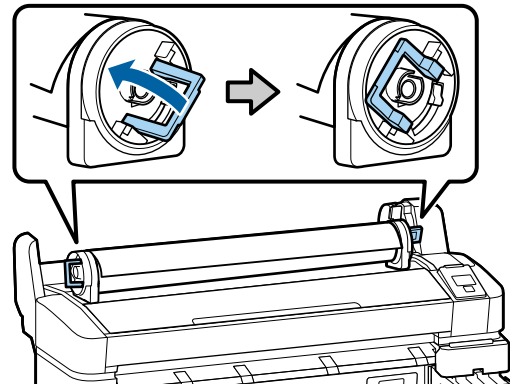

- Slide the roll paper right until it contacts the adapter guide, then slowly roll it backward following the adapter guide.

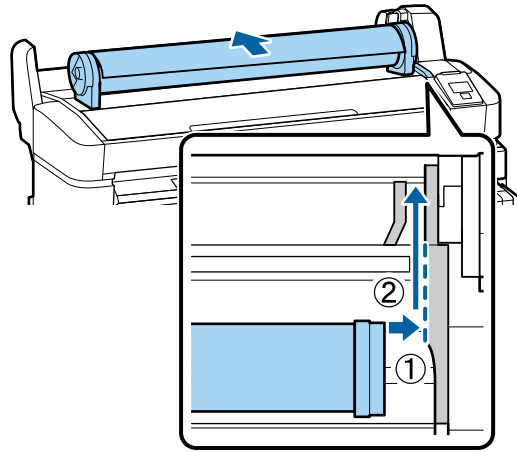

- Press the  load/remove paper button on the product control panel.

You see the **Roll Paper** message on the product control panel screen. Press the **OK** button.

- Insert the roll paper into the opening in the product and pull it through, making sure there is no slack in the paper and the ends do not fold.

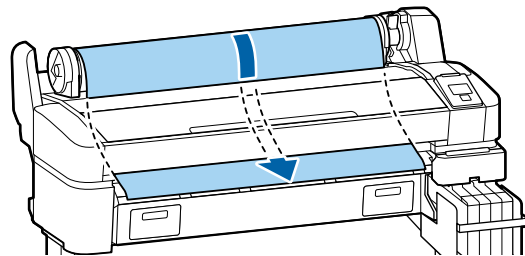



**Note:** Avoid touching the printable surface of the paper. Rotate the roll paper adapters as shown to feed paper.

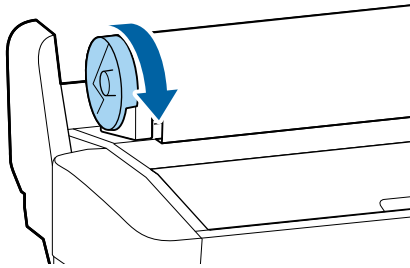

12. Lower the adapter holder lock lever.

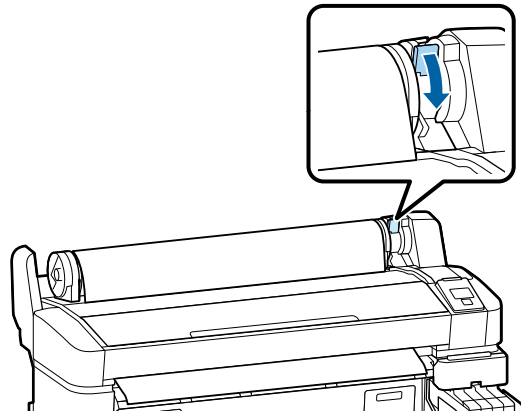

Instructions appear on the product control panel screen.

13. Press the **OK** button.

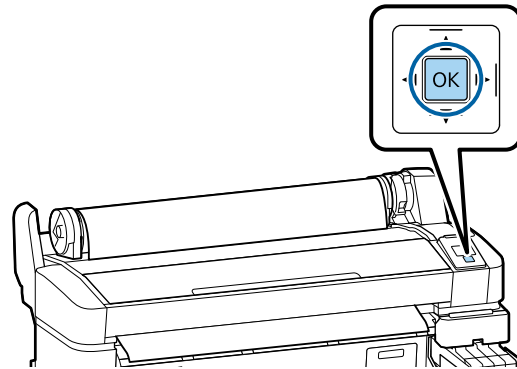

Paper feeds into the printer.

14. Close the roll paper cover.

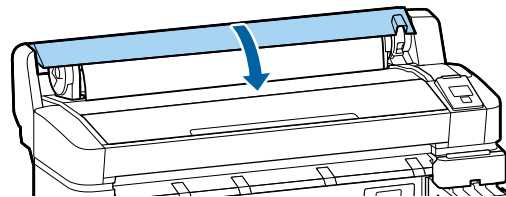

15. Select your media settings on the control panel.

**Parent topic:** [Media Handling](#)

**Related references**

[Handling Media](#)

**Related tasks**

[Viewing and Changing Media Settings](#)

## Viewing and Changing Media Settings

After you load media in your product, you see a screen like this on your product control panel which lets you view or change your media settings:

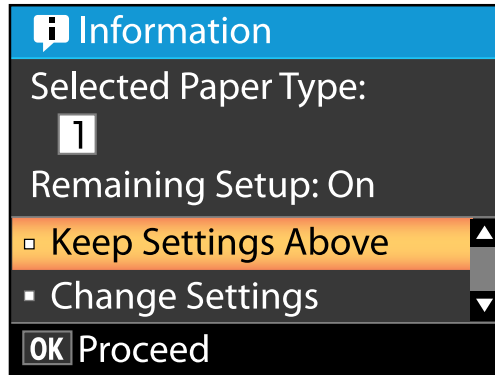

The media settings include the options selected and stored for each media bank or RIP setting you created.

1. Do one of the following:
  - If the displayed media settings are correct for the media you loaded, press the up or down arrow button to select **Keep Settings Above** and press the **OK** button.
  - If you need to change the media settings, press the up or down arrow button to select **Change Settings** and press the **OK** button.
2. If you want your product to calculate the amount of media remaining based on the length of the roll and the amount already printed, and display the approximate results on the product control panel, set the **Remaining Setup** setting to **On**.
3. To change your media settings, select the setting you want to change and press the **OK** button. Then press the ↵ back button and repeat this step to select additional settings as necessary.
4. When you finish changing media settings, press the up or down arrow button to select **Exit** and press the **OK** button.
5. If you turned on the **Remaining Setup** setting, you see a prompt to enter the length of the current media.

6. Press the up or down arrow button to select a roll length from 15 to 3000 feet (5 and 999.5 m) long and press the **OK** button.

**Note:** You can select the roll length in 19.7 inch (0.5 m) increments.

After a moment you see the message **Ready** on the product control panel indicating that it is ready to print.

**Parent topic:** [Media Handling](#)

**Related tasks**



[Saving Sets of Media Settings](#)

## Saving Sets of Media Settings

You can store sets of media settings for each type of media you use. This lets you quickly select all the necessary settings whenever you print on that media type.

The media settings include the options selected and stored for each media bank or RIP setting you created.

**Note:** Make sure that you loaded the media type for which you are selecting settings.

1. On the product control panel, press the left or right arrow button to select the  tab and press the **OK** button.  
The Paper menu appears.
2. Press the up or down arrow button to select **Custom Paper Setting** and press the **OK** button.  
The Custom Paper Setting menu appears.
3. Press the up or down arrow button to select a number for the set of media settings (from 1 to 10) and press the **OK** button.
4. To select a reference media type that is close to the characteristics of the media you are adding, select **Select Reference Paper** and press the **OK** button.
5. Press the up or down arrow button to select the reference media type and press the **OK** button.
6. Press the  back button twice to return to the paper settings menu.
7. Press the up or down arrow button to select **Setting Name** and press the **OK** button.
8. Press the up or down arrow button to display the letters and symbols you can use to name the media setting. When you see the desired character, press the right arrow button to move to the next

character position and repeat this step as necessary to complete the setting name. When you finish, press the **OK** button.

**Note:** If you need to delete the previous character, press the left arrow button.

9. Press the up or down arrow button as necessary to select each available media setting and press the **OK** button. If necessary, press the ↶ back button to return to the menu to select additional settings.

**Parent topic:** [Media Handling](#)

**Related tasks**

[Loading Media](#)

## Printable Area and Media Size Checking

The left and right edges of media recognized by your product vary depending on the **Roll Paper Margin** and **Select Paper Type** settings.

- When the **Roll Paper Margin** setting is set to **Normal**, your product sets the top and bottom margins to 0.6 inch (15 mm) and the side margins to 0.12 inch (3 mm).
- When the **Roll Paper Margin** setting is set to a different option, the margin size varies depend on the setting and on the number of passes selected in your RIP software, as described in the following tables.

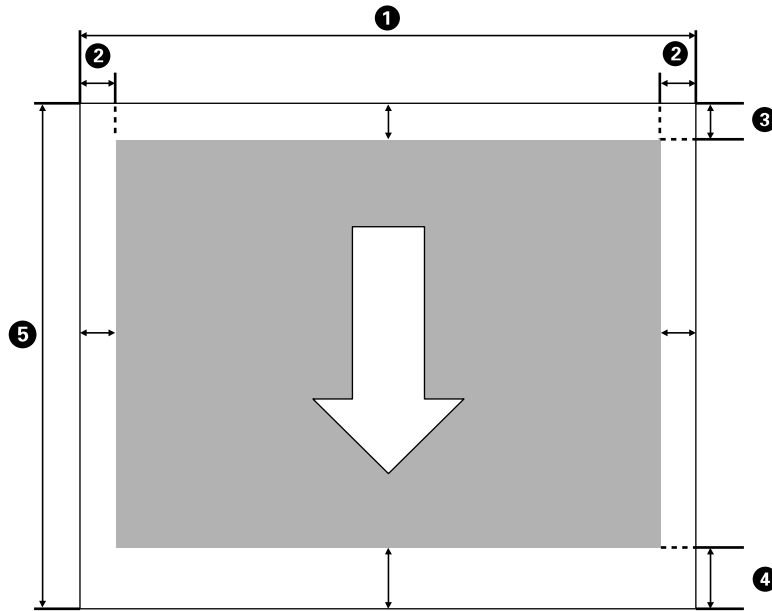

- 1 Maximum media width
- 2 Side margins
- 3 Bottom margin
- 4 Top margin
- 5 Maximum media length

Roll Paper Margin setting	Margins
<b>Normal</b>	Top and bottom margins: 0.6 inch (15 mm) Side margins: 0.12 inch (3 mm)
<b>Top15mm/Bottom15mm</b>	Top and bottom margins: 0.6 inch (15 mm) Side margins: 0.12 inch (3 mm)
<b>Top35mm/Bottom15mm</b>	Top margin: 0.6 inch (15 mm) Bottom margin: 1.38 inches (35 mm) Side margins: 0.12 inch (3 mm)

Roll Paper Margin setting	Margins
<b>Top15mm/Bottom150mm</b>	Top margin: 0.6 inch (15 mm) Bottom margin: 5.9 inches (150 mm) Side margins: 0.12 inch (3 mm)
<b>Top5mm/Bottom5mm</b>	Top and bottom margins: 0.2 inch (5 mm) Side margins: 0.12 inch (3 mm)
<b>15mm</b>	All margins 0.6 inch (15 mm)

**Note:** If you selected **Normal** and one of these options as the **Select Paper Type** setting, the top margin is 0.79 inch (20 mm):

- **Premium Glossy 250**
- **Premium Semigloss 250**
- **Premium Luster 260**
- **Premium Semimatte 260**

**360 × 720 2 pass mode**

Roll Paper Margin setting	Margins
<b>Normal</b>	Top margin: 1.14 inches (29 mm) Bottom margin: 0.6 inch (15 mm) Side margins: 0.12 inch (3 mm)
<b>Top15mm/Bottom15mm</b>	Top margin: 1.14 inches (29 mm) Bottom margin: 0.6 inch (15 mm) Side margins: 0.12 inch (3 mm)
<b>Top35mm/Bottom15mm</b>	Top margin: 1.92 inches (49 mm) Bottom margin: 0.6 inch (15 mm) Side margins: 0.12 inch (3 mm)

<b>Roll Paper Margin setting</b>	<b>Margins</b>
<b>Top15mm/Bottom150mm</b>	Top margin: 1.14 inches (29 mm) Bottom margin: 5.9 inches (150 mm) Side margins: 0.12 inch (3 mm)
<b>Top5mm/Bottom5mm</b>	Top margin: 0.75 inch (19 mm) Bottom margin: 0.2 inch (5 mm) Side margins: 0.12 inch (3 mm)
<b>15mm</b>	Top margin: 1.14 inches (29 mm) Bottom and side margins: 0.6 inch (15 mm)

**360 × 720 3 pass mode**

<b>Roll Paper Margin setting</b>	<b>Margins</b>
<b>Normal</b>	Top margin: 1.22 inches (31 mm) Bottom margin: 0.6 inch (15 mm) Side margins: 0.12 inch (3 mm)
<b>Top15mm/Bottom15mm</b>	Top margin: 1.22 inches (31 mm) Bottom margin: 0.6 inch (15 mm) Side margins: 0.12 inch (3 mm)
<b>Top35mm/Bottom15mm</b>	Top margin: 2.0 inches (51 mm) Bottom margin: 0.6 inch (15 mm) Side margins: 0.12 inch (3 mm)
<b>Top15mm/Bottom150mm</b>	Top margin: 1.22 inches (31 mm) Bottom margin: 5.9 inches (150 mm) Side margins: 0.12 inch (3 mm)
<b>Top5mm/Bottom5mm</b>	Top margin: 0.83 inch (21 mm) Bottom margin: 0.2 inch (5 mm) Side margins: 0.12 inch (3 mm)



Roll Paper Margin setting	Margins
15mm	Top margin: 1.22 inches (31 mm) Bottom and side margins: 0.6 inch (15 mm)

**Note:** If you selected **Normal** and one of these options as the **Select Paper Type** setting, the top margin is 0.2 inch (5 mm):

- **Premium Glossy 250**
- **Premium Semigloss 250**
- **Premium Luster 260**
- **Premium Semimatte 260**

Parent topic: [Media Handling](#)

#### Related references

[Paper Menu Settings](#)

[Setup Menu Settings](#)

## Adjusting the Media Feed

If your printouts contain horizontal banding, uneven tint, or stripes, you need to adjust the feed of the media. You do this by printing and examining a test pattern, and then selecting the feed adjustments you need.

Adjust the feed using the same media type and print conditions you use for printing. You may need to adjust the feed again if you load media of a different width, change the feeding tension, or adjust the suction.

Before adjusting the feed, make sure you have correctly loaded the media you plan to print on and selected all the options you plan to use for printing.

**Note:** You can also adjust the feed during printing without printing a test pattern.

1. On the product control panel, press the left or right arrow button to select the  tab and press the **OK** button.  
The Paper menu appears.
2. Press the up or down arrow button to select **Custom Paper Setting** and press the **OK** button.  
The Custom Paper Setting menu appears.

3. Press the up or down arrow button to select a number for the set of media settings (from 1 to 10) and press the **OK** button.
4. Press the up or down arrow button to select **Paper Feed Adjust** and press the **OK** button.
5. Do one of the following:
  - To print an adjustment pattern, select **Pattern** and press the **OK** button. Press the **OK** button again to print an adjustment pattern and go to the next step.
  - To manually enter an adjustment value, select **Value** and press the **OK** button. Press the up or down arrow buttons to select an adjustment value and press the **OK** button.
6. Measure the distance between the **+** symbols in the printed test pattern.

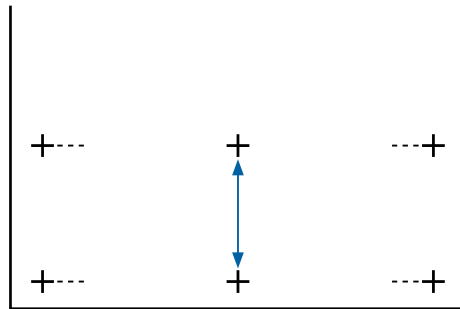

7. Press the up or down arrow button to select the measured distance and press the **OK** button.

[Adjusting the Media Feed During Printing](#)

**Parent topic:** [Media Handling](#)

**Related tasks**

[Loading Media](#)

## Adjusting the Media Feed During Printing

Follow the steps here to adjust the feed during printing without printing a test pattern.

1. During printing, press the  cut/feed media button.  
The product control panel displays an adjustment value.

2. Press the up or down arrow button to adjust the feed depending on these banding results in your printout:
  - If black bands or dark stripes appear, press the up arrow button to increase the feed amount.
  - If white bands or pale stripes appear, press the down arrow button to decrease the feed amount.
3. Check the results in your printout and do one of the following:
  - If further adjustment is necessary, repeat the last step.
  - If the print quality is good, press the **OK** button.

**Parent topic:** [Adjusting the Media Feed](#)

## Cutting Media

When you finish printing, do one of the following to cut the media:

- If you turned on the **Auto Cut** setting on the product control panel, your product automatically cuts the media after printing each page.
- If you did not turn on the **Auto Cut** setting, follow the instructions here to cut the media manually.

**Note:** The minimum length of paper that you can cut with the built-in cutter is 2.36 inches (60 mm). If your printed image is smaller, the built-in cutter must leave a margin that you can trim using a commercially available cutter after removing the media from the product.

1. Press the  cut/feed media button, look through the printer cover, and press the down arrow button as necessary to align the cut position with the arrow inside the printer.

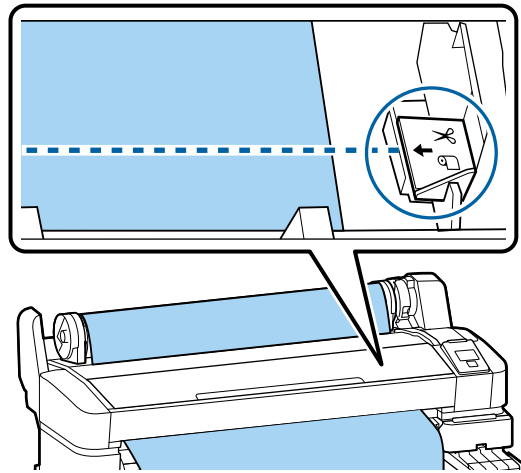

2. Press the **OK** button.  
The printer slowly cuts the media.

**Parent topic:** [Media Handling](#)

**Related references**  
[Setup Menu Settings](#)

## Removing Media

After printing, remove the roll paper from your product for the best results.

**Caution:** Always remove media after printing. This avoids creases in the media that may be caused by the pressure rollers. Creased, wavy, or curled media could cause it to jam inside the printer or contact the print head.

1. Press the  load/remove paper button.  
The Load/Remove Paper menu appears on the product control panel screen.
2. Press the up or down arrow button to select **Remove Paper** and press the **OK** button.

The printer automatically rewinds the paper onto the roll and displays this message: **Press  and load paper.**

**Note:** If you see a message telling you to turn the roll paper adapter, rewind the paper by hand using the adapter instead.

3. Open the roll paper cover.

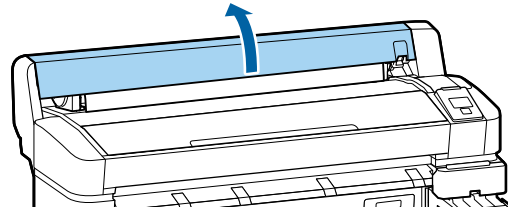

4. Lift up the adapter holder lock lever.

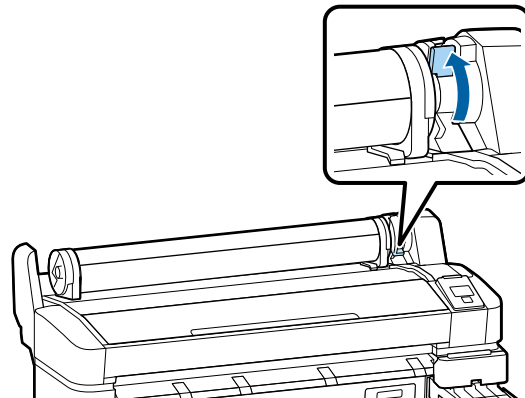

5. Holding the roll by the roll paper adapters, move the media to the roll rest temporarily.

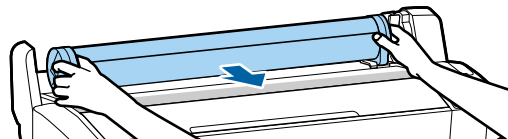

- Lift up the lock levers on both roll paper adapters.

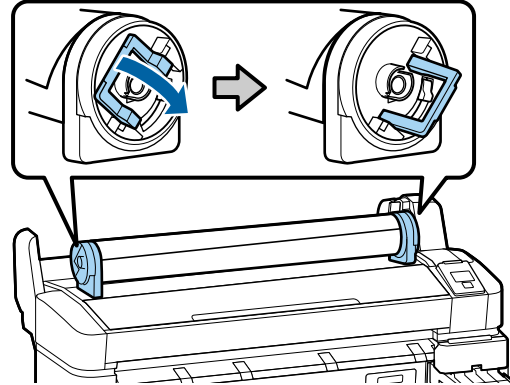

- Remove the roll paper adapters from each end of your media roll.

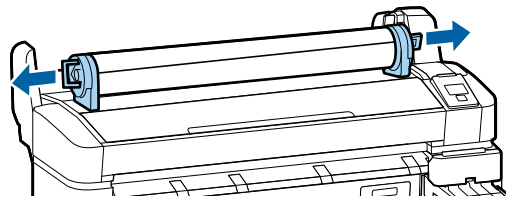

- Carefully rewind the media onto the roll and store it in its original packaging.

**Parent topic:** [Media Handling](#)

---

# Using the Control Panel Menus

Follow the instructions in these sections to access the printer menu system and select settings.

[Accessing the Printer's Menus](#)

[Paper Menu Settings](#)

[Maintenance Menu Settings](#)

[Setup Menu Settings](#)

## Accessing the Printer's Menus

You can use the printer menus to adjust the settings that control how your product works.

1. Press the **Menu** button on the control panel.  
You see the menu for the current tab on the LCD screen.
2. Press the up or down arrow button to scroll through the settings.

**Note:** Press the  back button to go back.

3. To change the highlighted setting, press the **OK** button.
4. Press the up or down arrow button to scroll through the options.
5. To select an option, press the **OK** button.
6. Press the right or left arrow button to switch between tabs. You can also use these buttons to position the cursor when entering data on the screen.
7. When you finish changing settings on a menu, press the  pause/cancel button to exit the menu.

**Parent topic:** [Using the Control Panel Menus](#)

## Paper Menu Settings

Settings on the Paper menu let you customize various adjustments for up to 10 different types of paper.

**Caution:** Follow the instructions in the topic links below the table to use these menu settings correctly.

Setting	Options	Description
Load/Remove Paper	Remove Paper	Displays instructions for removing paper.
	Roll Paper	Displays instructions for loading paper.
Select Paper Type	1 to 10 (Paper Settings Number)	Lists the names of user-defined paper types.
	RIP Settings	Specifies using the software RIP settings instead of the printer settings.
Custom Paper Setting	—	See the next table.
Print Paper List	—	Press the <b>OK</b> button to print a list of custom paper settings.

#### Custom Paper Setting options

Options	Description
Select Reference Paper	Select the type of paper that is closest to the paper you are using: <b>Photo Paper</b> <b>Matte Paper</b> <b>Plain Paper</b> <b>Others</b> <b>No Paper Selected</b>
Platen Gap	Select <b>Standard</b> for most media. Select <b>Narrow</b> if head alignment does not completely align the print head. Select <b>Wide</b> or <b>Wider</b> if printouts are smeared.
Detect Paper Thickness	Prints patterns that you can use to determine the thickness of the current paper. Lets you select the pattern number with the least misalignment.



Options	Description
<b>Paper Feed Adjust</b>	Use this setting if you are unable to resolve banding issues even after head cleaning and alignment. Select one of the following:  <b>Pattern:</b> prints an adjustment pattern that you can measure and then enter the measured distance.  <b>Value:</b> lets you choose an adjustment between <b>-0.70</b> and <b>+0.70%</b> . Select a higher value to reduce dark bands, or a lower value to reduce white bands.
<b>Paper Suction</b>	Set from <b>-4</b> to <b>0</b> to increase the gap between the print head and thin or soft paper. If print quality is reduced or media does not feed correctly, you may need to lower the suction.
<b>Roll Paper Tension</b>	Select <b>High</b> or <b>Extra High</b> if paper wrinkles during printing.
<b>Remove Skew</b>	Select <b>On</b> to enable paper skew reduction.
<b>Setting Name</b>	Enter a name up to 22 characters for the custom paper settings.
<b>Restore Settings</b>	Select <b>Yes</b> to return all settings for the selected custom paper to their default values.

**Parent topic:** [Using the Control Panel Menus](#)

**Related tasks**

[Loading Media](#)

[Saving Sets of Media Settings](#)

[Adjusting the Media Feed](#)

## Maintenance Menu Settings

The Maintenance menu lets you run nozzle checks, cleaning cycles, and other maintenance operations. You can access the menu directly by pressing the **M** maintenance button.

**Caution:** Follow the instructions in the topic links below the table to use these menu settings correctly.

Setting	Options	Description
<b>Nozzle Check</b>	—	Prints a nozzle check pattern that you can visually inspect and then run head cleaning if necessary.
<b>Head Cleaning</b> <b>All Nozzles</b> <b>Selected Nozzles</b>	<b>Execute (Light)</b> <b>Execute (Medium)</b> <b>Execute (Heavy)</b>	Lets you clean all or selected nozzles, based on the nozzle check pattern. Select the lightest cleaning level first. If nozzles are still clogged, select a heavier cleaning.
<b>Head Alignment</b>	<b>Manual(Uni-D)</b> <b>Manual(Bi-D)</b>	Select when print results are grainy or out of focus:  <b>Manual(Uni-D):</b> when printing in one direction.  <b>Manual(Bi-D):</b> when printing in both directions. If head alignment with this setting does not correct the problem, select <b>Manual(Uni-D)</b> .
<b>Cutter Maintenance</b>	<b>Adjust Cut Position</b> <b>Replace Cutter</b>	Adjusts the cutter position in increments of 0.039 inch (1 mm), from –0.12 to 0.12 inch (–3 to 3 mm).  <b>Replace Cutter:</b> positions the cutter for replacement.
<b>Head Maintenance</b>	<b>Move Head</b>	Positions the print head for cleaning using the head maintenance kit.
<b>Waste Ink Counter</b>	—	Lets you reset the waste ink counter if you replace the waste ink bottle before being prompted by a message on the control panel.

Parent topic: [Using the Control Panel Menus](#)

#### Related tasks

[Checking for Clogged Print Head Nozzles](#)

[Cleaning the Print Head](#)

[Aligning the Print Head](#)

[Replacing the Cutter](#)

[Performing Head Maintenance](#)  
[Replacing the Waste Ink Bottle](#)

## Setup Menu Settings

The Setup menu lets you configure and monitor the following aspects of your product:

- Printer setup
- Printer status
- Network setup
- Power settings
- General preferences
- Date and time settings

**Caution:** Follow the instructions in the topic links below the tables to use these menu settings correctly.

### Printer Setup Settings

Setting	Options	Description
<b>Roll Paper Setup</b>	<b>Auto Cut</b>	Automatically cuts the roll paper as each page is printed.
	<b>Page Line</b>	Prints a cut line between pages if <b>Auto Cut</b> is off.
	<b>Roll Paper Margin</b>	Sets the top and bottom margins for each page. <b>Normal:</b> top and bottom margins are 0.59 in. (15 mm), left and right margins are 0.12 in. (3 mm). <b>15mm:</b> all margins are 0.59 in. (15 mm). All other settings: left and right margins are 0.12 in. (3 mm), top and bottom as indicated.
	<b>Roll Paper Remaining</b>	Displays and records the amount of paper remaining on a roll (after you enter the total roll length).
	<b>Remaining Alert</b>	Enter the length at which the printer will alert you, from <b>4</b> to <b>50</b> ft ( <b>1</b> to <b>15</b> m).

Setting	Options	Description
<b>Advanced Settings</b>	<b>Roll Paper Tension</b>	If paper wrinkles, select <b>High</b> or <b>Extra High</b> (applies only if no custom roll paper tension is set).
	<b>Less Head Scuffing</b>	Prevents scuffing when printing on thick paper. This temporarily changes the <b>Platen Gap</b> setting, unless it is already set to <b>Wider</b> .
	<b>Drying Time Per Page</b>	If ink blurs on the paper, set a time from <b>0.1</b> to <b>60</b> minutes.
	<b>Paper Size Check</b>	Automatically detects the edges of the paper. Turn off this setting only if the printer displays a paper setting error when media is loaded correctly. Changed settings take effect when paper is reloaded.
	<b>Paper Skew Check</b>	Stops printing when skewed paper is detected. Leave this setting <b>On</b> to avoid paper jams.
	<b>Print Nozzle Pattern</b>	Selects how often to print an automatic nozzle check pattern (from <b>1</b> to <b>10</b> pages).
	<b>Periodical Cleaning</b>	Selects the strength ( <b>Light</b> , <b>Medium</b> , or <b>Heavy</b> ) and frequency of automatic head cleaning cycles. Even when <b>Off</b> , the printer automatically cleans the print head at set intervals to prevent clogging.
	<b>Cleaning Cycle</b>	Selects the frequency of automatic head cleaning cycles ( <b>OFF</b> or from <b>1</b> to <b>10</b> pages).
<b>Restore Settings</b>	—	Returns all printer settings to their default values.

### Printer Status Settings

Setting	Options	Description
<b>Firmware Version</b>	xxxxxxx,x.xx,xxxx	Displays the printer's firmware version.
<b>Option Status</b>	—	No options available.
<b>Show total prints</b>	—	Shows total media printed in feet <sup>2</sup> or m <sup>2</sup> .

Setting	Options	Description
Print Status Sheet	—	Prints a sheet showing current printer settings.

### Network Setup Settings

Setting	Options	Description
IP Address Setting	Auto Panel	Determines whether IP addresses are obtained automatically through DHCP or manually. Select <b>Panel</b> to enter an IP address, subnet mask, and default gateway address.
Print Status Sheet	—	Prints the current network status and settings.
Restore Settings	Yes No	Restores all network settings to their defaults.

### Power Settings

Setting	Options	Description
Sleep Mode	5 to 240 minutes	Selects the interval before the printer enters sleep mode.
Power Off Timer	Off 1 to 24 hours	Selects the interval before the printer turns off automatically when it is idle. Default is <b>8 hours</b> .
Restore Settings	Yes No	Restores all Power settings to their defaults.

### Preferences Settings

Setting	Options	Description
Language	Various languages	Selects the language used on the control panel display.

Setting	Options	Description
<b>Unit: Length</b>	m ft/in	Selects the unit of length used on the control panel display and when printing test patterns.
<b>Alert Lamp Setting</b>	On Off	Enables the alert light when an error occurs.

#### Administrator Menu Settings

Setting	Options	Description
<b>Date And Time</b>	MM/DD/YY HH:MM	Sets the printer's built-in clock. The time and date are used in logs and status sheets.
<b>Time Zone</b>	—	Enter the difference between your time zone and GMT. The time zone is used in email notifications sent by the Remote Manager utility.
<b>Restore All Settings</b>	Yes No	Restores all Setup menu settings to their defaults (except <b>Date and Time</b> , <b>Language</b> , and <b>Unit: Length</b> ).

**Parent topic:** [Using the Control Panel Menus](#)

#### Related references

[Printable Area and Media Size Checking](#)

#### Related tasks

[Saving Sets of Media Settings](#)

[Cutting Media](#)

[Checking for Clogged Print Head Nozzles](#)

[Cleaning the Print Head](#)

---

# Maintenance

See the instructions in these sections to maintain your printer for optimum results.

[Maintenance Precautions](#)

[Cleaning the Product](#)

[Stirring High Density Black Ink](#)

[Replacing the Ink and Chip Unit](#)

[Print Head Maintenance](#)

[Replacing the Waste Ink Bottle](#)

[Replacing the Cutter](#)

## Maintenance Precautions

Follow these precautions as you maintain your product:

- Remove loaded media from the product before performing any maintenance tasks.
- Touch a metal object to discharge any static electricity before performing any maintenance tasks.
- Store ink packs, waste ink, and ink cleaner out of the reach of children.
- Wear protective eyewear, gloves, and a mask when performing maintenance tasks.
- After performing maintenance, wash your hands thoroughly.
- Do not use anything other than the cleaning pads to maintain your product or you may damage its print head.
- Always use fresh cleaning pads.

**Warning:** If ink, waste ink, or ink cleaner contact your skin, or get into your eyes or mouth, immediately do the following:

- Thoroughly wash the ink, waste ink, or ink cleaner from your skin with soapy water. If your skin becomes irritated or discolored, contact a doctor.
- Immediately rinse the ink, waste ink, or ink cleaner from your eyes with water to avoid bloodshot eyes or mild inflammation. If you experience eye problems, contact a doctor.
- If ink, waste ink, or ink cleaner gets in your mouth, contact a doctor immediately.
- If you swallow ink, waste ink, or ink cleaner, do not induce vomiting and contact a doctor immediately. Inducing vomiting may cause material to get in your windpipe and cause injury.



**Caution:** Waste ink is classified as industrial waste. Dispose of waste ink according to your local laws and regulations such as entrusting it to an industrial waste disposal company. When handing over the waste ink to the industrial waste disposal company, make sure you include the Safety Data Sheet (SDS) found on Epson's support website.

**Parent topic:** [Maintenance](#)

**Related tasks**

[Removing Media](#)

[Performing Head Maintenance](#)

## Cleaning the Product

Clean your product periodically, and if you notice it is dirty on the inside or outside.

**Caution:** If dust or other particles remain on the platen inside the product, the print head nozzles may clog or the print head may be damaged.

1. Remove any paper from the product.
2. Turn off the product and disconnect the power cable from the electrical outlet.
3. Use a soft, clean cloth to carefully remove any dust or dirt from the exterior of the product.
4. To remove stubborn dirt, dampen the cloth with mild detergent, wipe the surface, and wipe it dry with a clean dry cloth.

**Caution:** Do not use a hard brush, benzene, alcohol, or paint thinner to clean the product or you may damage it.

5. Open the printer cover and use a soft, clean cloth to carefully clean platen area (a) as shown here. Wipe from the inside of the printer toward the outside to avoid spreading dirt.

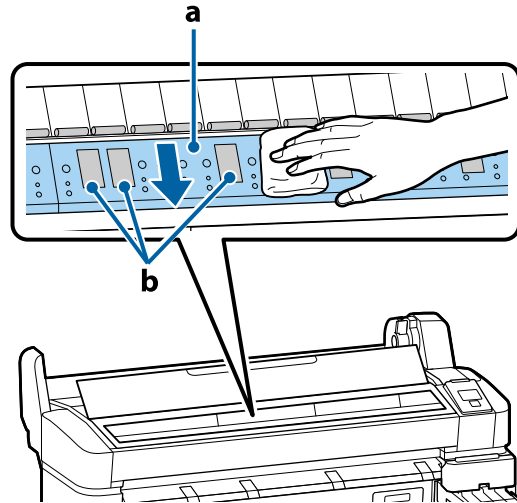

**Caution:** As you clean, do not touch the ink tubes, rollers, or platen area (b) shown here to avoid staining future prints. If necessary, clean area (a) using a cloth dampened with mild detergent and wipe dry with a soft cloth.

6. If any paper dust accumulates in the platen holes, gently remove it using a pointed object.

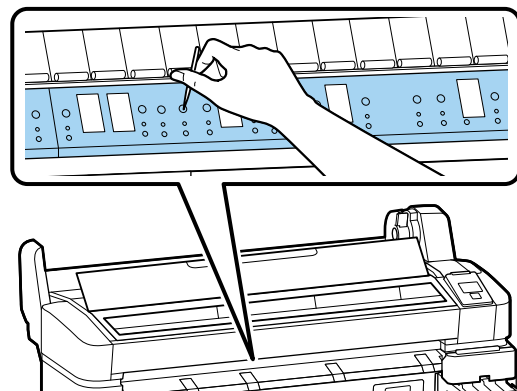

7. Close the printer cover.
8. Plug in and turn on the product, then load roll paper.
9. To clean the pressure rollers, press the  cut/feed media button, then hold down the down arrow button to feed paper over the rollers.
10. Cut the media after feeding.

**Parent topic:** [Maintenance](#)

**Related references**

[Maintenance Precautions](#)

**Related tasks**

[Removing Media](#)

[Cutting Media](#)

## Stirring High Density Black Ink

To prevent sedimentation and incorrect colors in your printed media, stir the High Density Black ink in the ink tank once a week.

1. Open the ink inlet cover for the High Density Black ink shown here.

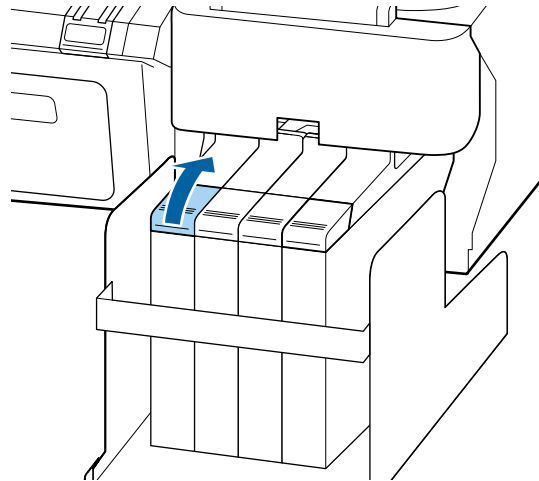

2. Grasp the loop at the top of the ink inlet cap and slowly remove the ink inlet cap.

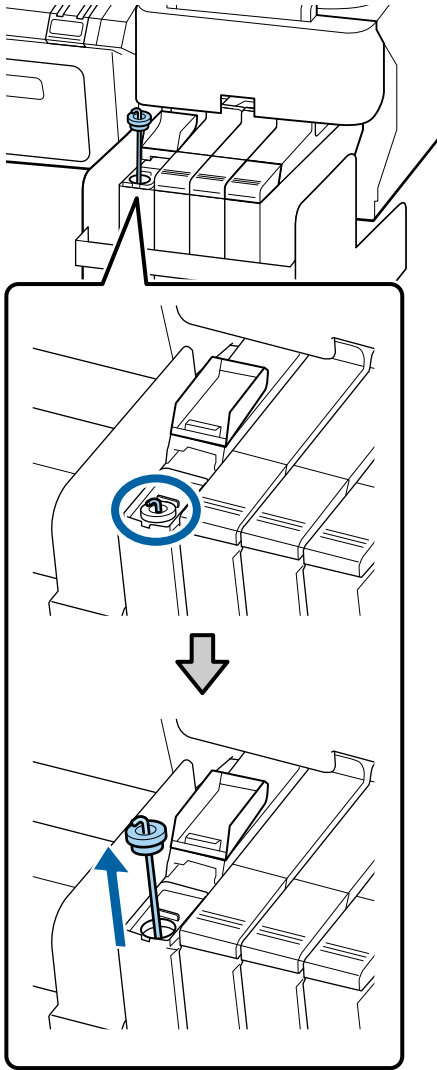

3. Move the stirring stick up and down 15 times. Insert the stick completely into the ink tank and raise the stick up to the top each time.

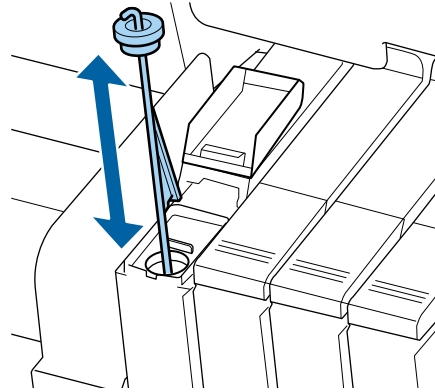

**Caution:** Move the stick slowly and steadily, or ink may splatter.

4. Insert the stirring stick into the ink tank and replace the ink inlet cap

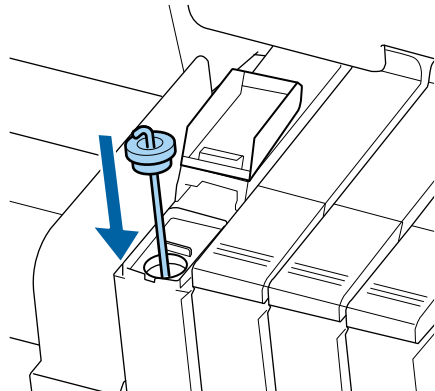

**Caution:** Press the ink inlet cap down firmly. If the slider comes into contact with the ink inlet cap when pulling it out, the cap could get damaged.

5. Close the ink inlet cover.

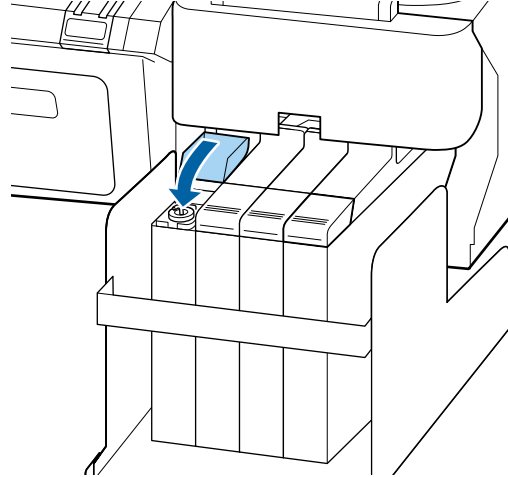

**Parent topic:** [Maintenance](#)

**Related references**

[Maintenance Precautions](#)

## Replacing the Ink and Chip Unit

See these sections to replace the ink chip unit in your product.

[About Ink and Chip Unit Replacement](#)

[Ink and Chip Unit Precautions](#)

[Replacing the Chip Unit and Refilling Ink](#)

**Parent topic:** [Maintenance](#)

**Related references**

[Consumables and Replacement Parts](#)

## About Ink and Chip Unit Replacement

When the message **Check Ink Levels** is displayed on the control panel screen, you need to refill the ink and replace the chip unit soon. Obtain an ink pack of the appropriate color as soon as possible.

You will be unable to print if a chip unit needs to be replaced. If the **Check Ink Levels** message is displayed during a print job, the print job pauses while you refill the ink and replace the chip unit. You can use the same procedure to refill the ink and replace chip units for all colors.

**Note:** When the message **Refill Ink Tank** is displayed on the control panel screen and the remaining ink level is greater than 2.8 in. (70 mm) from the base of the ink tank, it is time to replace the ink tank. The ink tank must be replaced because fine dirt, dust, and other foreign material causes the ink tank's filter to malfunction. The ink tank replacement interval depends on the usage environment and conditions. Contact Epson Support for information on replacing components.

**Note:** This printer has a remaining ink warning system. This system does not directly detect the amount of ink remaining in the ink tank. Instead, the amount of ink remaining is estimated based on the ink usage conditions and displayed as a message. The accuracy of this system depends on consistent and proper ink refills.

If the procedure for refilling the ink and replacing the chip unit is not followed correctly, the remaining ink warning system may not function properly. To prevent this, replace the chip unit and refill the ink as soon as possible once the remaining ink level falls below 2.8 in. (70 mm) from the base of the ink tank.

**Parent topic:** [Replacing the Ink and Chip Unit](#)

#### **Related tasks**

[Replacing the Chip Unit and Refilling Ink](#)

## **Ink and Chip Unit Precautions**

Follow these precautions as you refill the ink in your product:

- Store ink packs in a location out of the reach of children.
- Wear protective eyewear and gloves when refilling ink.
- Be sure to read the Safety Data Sheet (SDS) before using ink packs. You can download it from [epson.com/proimaging](http://epson.com/proimaging).
- Gently cut or tear off the ink pack spout seal. If you cut the ink pack spout seal too quickly, ink may splatter.
- Do not squeeze open ink packs. Ink may spill.
- Gently tilt the ink pack when pouring ink into the ink tank.
- Do not place anything on the ink tank or subject it to strong impacts, or the ink tank could detach.
- Epson recommends the use of genuine Epson ink packs.

- Epson cannot guarantee the quality or reliability of non-genuine ink. The use of non-genuine ink may cause damage that is not covered by Epson's warranties, and under certain circumstances, may cause erratic printer behavior.
- Information about non-genuine chip unit status may not be displayed, and use of non-genuine ink is recorded for possible use in service support.

**Warning:** Should ink contact your skin or enter your eyes or mouth, immediately take the following actions:

- If fluid contacts your skin, immediately wash it off using large volumes of soapy water. Consult a physician if the skin appears irritated or discolored.
- If fluid enters your eyes, rinse them immediately with water. Failure to observe this precaution could result in bloodshot eyes or mild inflammation. If problems persist, consult with a physician.
- If swallowed, do not induce vomiting and consult with a physician immediately. Inducing vomiting may cause material to get in your windpipe and cause injury.

**Parent topic:** [Replacing the Ink and Chip Unit](#)

## **Replacing the Chip Unit and Refilling Ink**

Follow the steps here to replace the chip unit and refill the ink in your product.



1. When the message **Check Ink Levels** appears on the control panel screen, use the scale on the ink pack to check how much ink is left in the ink tank.

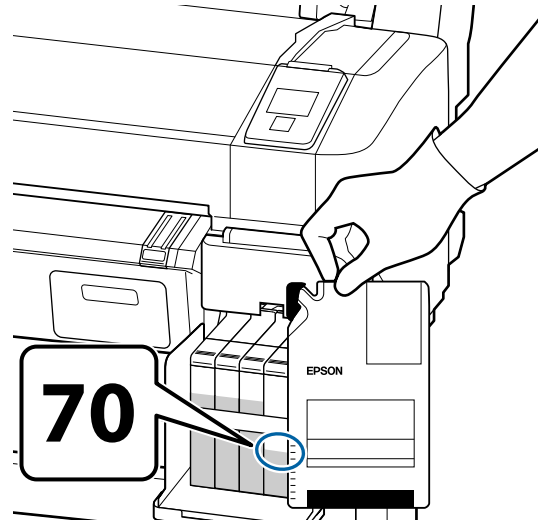

If the remaining ink level is greater than 2.8 in. (70 mm) from the base of the ink tank, continue to use the printer until the remaining ink level is 2.8 in. (70 mm) from the base of the ink tank so that you can use all the ink in a new ink pack to refill the ink tank.

If the remaining ink level is 2.8 inches (70 mm) or less, go to the next step.

**Note:** When the message **Refill Ink Tank** is displayed on the control panel screen and the remaining ink level is greater than 2.8 in. (70 mm) from the base of the ink tank, it is time to replace the ink tank. The ink tank must be replaced because fine dirt, dust, and other foreign material causes the ink tank's filter to malfunction. The ink tank replacement interval depends on the usage environment and conditions. Contact Epson Support for information on replacing components.

2. Open the ink cover.

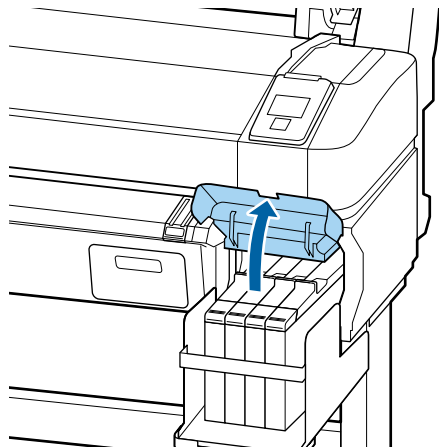

3. Insert a finger into the groove on the top of the slider and pull it straight out.

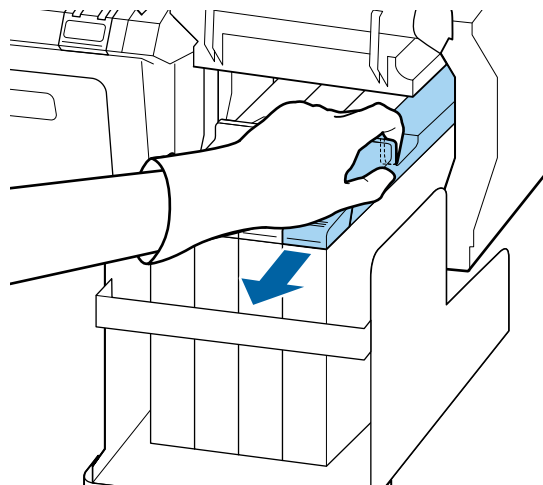

**Caution:** Do not tilt the slider. If you drop the chip unit, it may break.

4. Remove the chip unit from the slider.

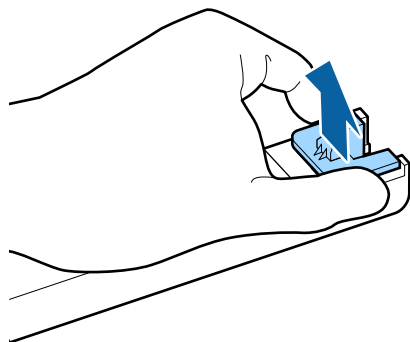

5. Confirm that the label color on the slider matches the label on the new ink pack. Then attach the chip unit supplied with the new ink pack to the slider.

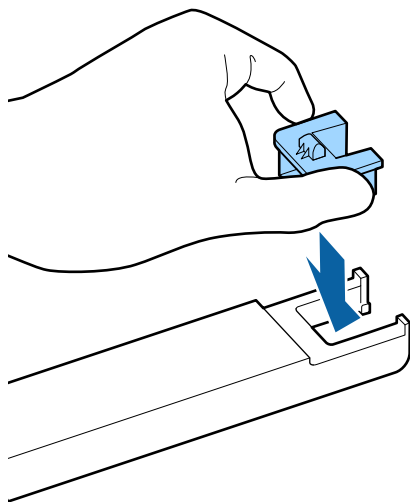

6. Hold the slider level and insert it. Then close the ink tank cover.

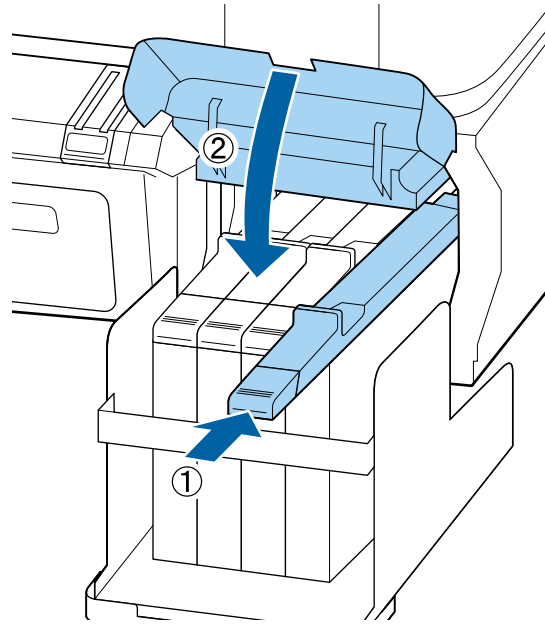

**Caution:** Do not push the slider in with too much force. Failure to observe this precaution could damage the printer.

7. Shake the new ink pack horizontally approximately 2 inches (5 cm) left and right for 5 seconds (approximately 15 times).

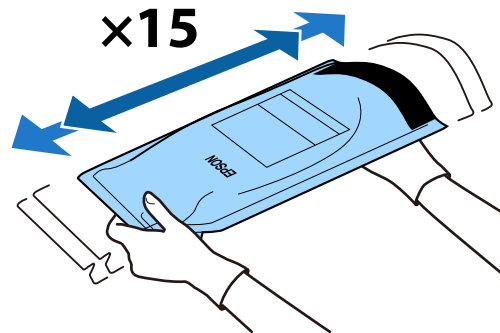

8. Open the slider ink inlet cover.

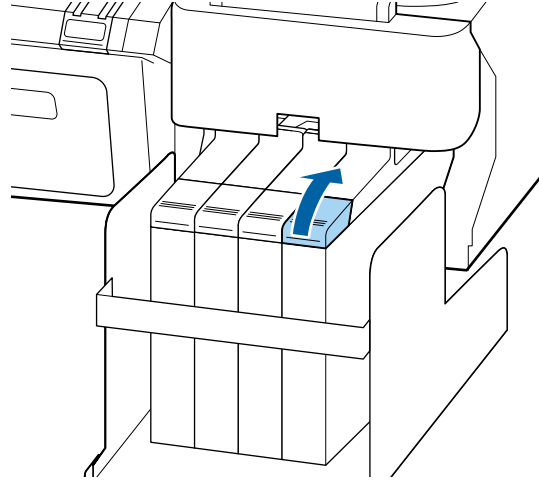

9. Do the following:

- For all ink colors except High Density Black ink, remove the ink inlet cap from the ink tank.

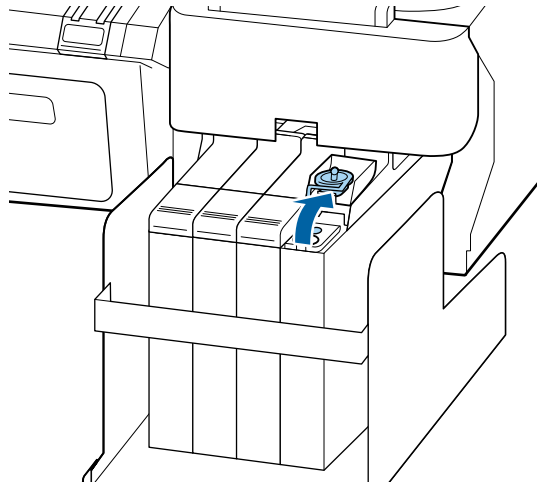

- For High Density Black ink, remove the ink inlet cap and stirring stick, then hook the stirring stick to the ink tank.

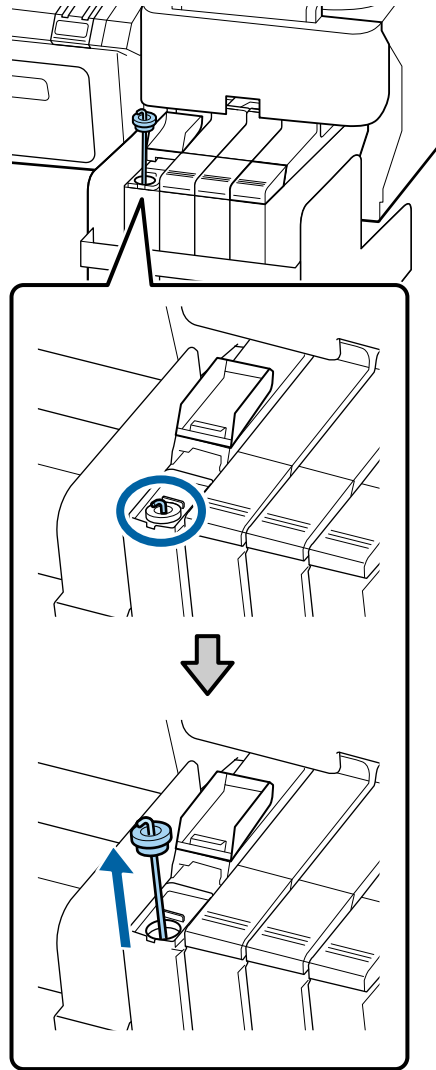

Rest the stirring stick on the tab at the edge of the tank as shown.

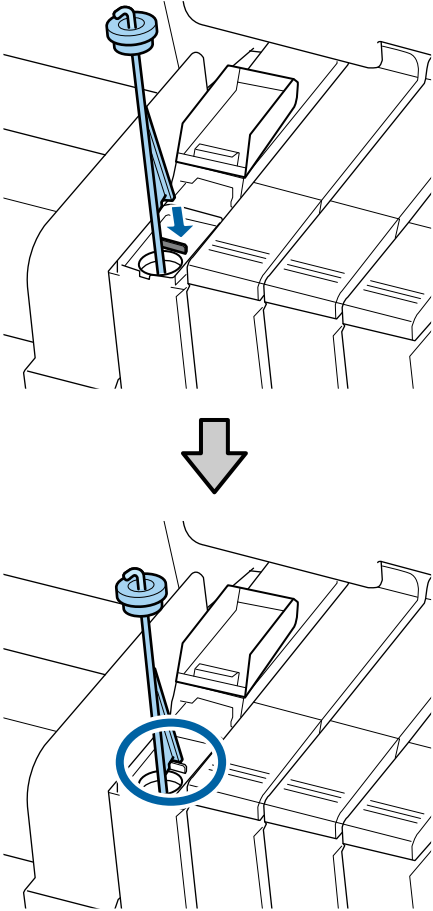

10. Cut or tear off the ink pack spout seal.

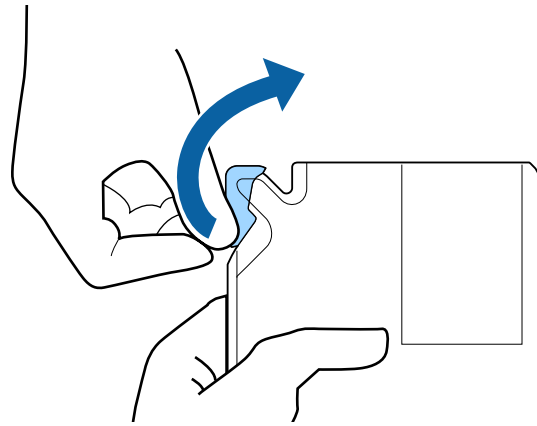



11. Insert the spout of the ink pack into the groove and slowly tilt it to pour the ink.

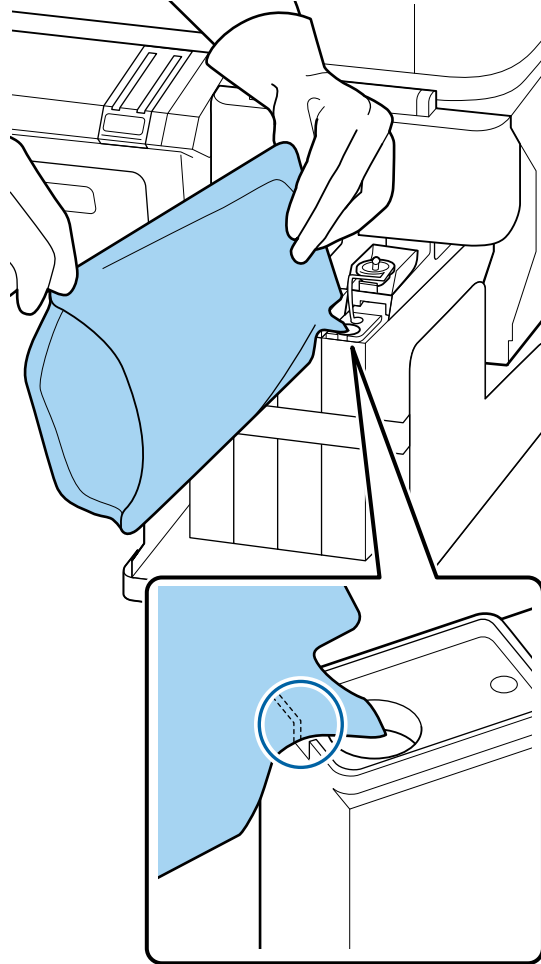

**Note:** Be sure to completely empty the ink pack into the tank. Do not use an ink pack to refill multiple ink tanks. This can prevent the proper display of messages from the remaining ink warning system.

12. Do the following:

- For all ink colors except High Density Black ink, replace the ink inlet cap.

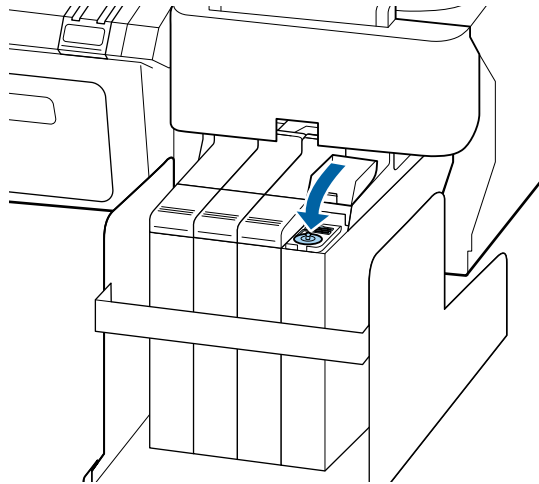

- For the High Density Black ink, lift up the stirring stick, guide it into the ink tank, and replace the ink inlet cap as shown.

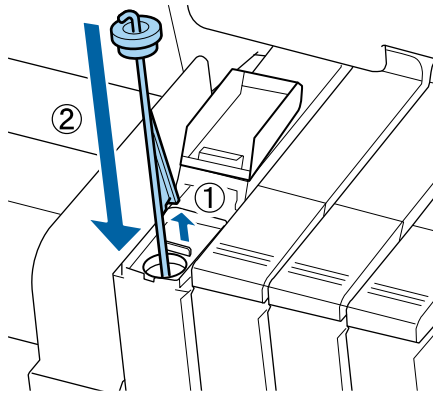

**Caution:** Press the ink inlet cap down firmly. If the slider comes into contact with the ink inlet cap when pulling it out, the cap could get damaged.

13. Close the slider ink inlet cover.

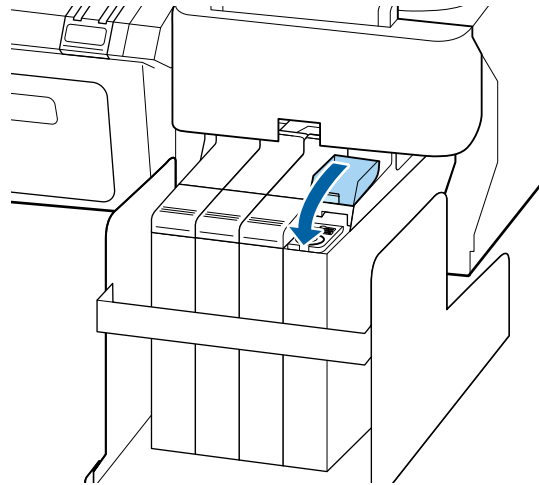

**Parent topic:** [Replacing the Ink and Chip Unit](#)

**Related concepts**

[About Ink and Chip Unit Replacement](#)

**Related references**

[Ink and Chip Unit Precautions](#)

[Consumables and Replacement Parts](#)

## Print Head Maintenance

Print head maintenance ensures the best print quality.

Perform the following maintenance as necessary:

- **Nozzle Check:** Check for clogged nozzles before each print job or if you have not used the printer for an extended period of time. Inspect the printed check pattern and clean the print head if you notice faint or missing areas.
- **Head Cleaning:** Clean the print head if you notice faint areas or gaps in the printed result.
- **Head Alignment:** Align the print head if your printouts are grainy or out of focus.

[Checking for Clogged Print Head Nozzles](#)

[Cleaning the Print Head](#)

## Checking for Clogged Print Head Nozzles

To maintain optimum print quality, perform a nozzle check before printing. This lets you visually inspect the printed check pattern and clean the nozzles, if necessary. There are two ways to check the nozzles:

- Set up the product to automatically print a check pattern before each print job. You can select how often the product performs a nozzle check in the **Setup** menu.
- Manually run a nozzle check from the product control panel, as described here.

1. Load roll paper and select the matching paper type on the product control panel.

2. Press the **Maintenance** button.

You see the **Maintenance** menu on the product control panel screen.

3. Select **Nozzle Check** and press the **OK** button.

You see a confirmation message.

4. Press the **OK** button.

The product prints a nozzle check pattern.

5. Check the printed pattern to see if there are gaps in the lines.

### Nozzles are clean

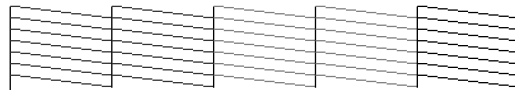

### Nozzles need cleaning

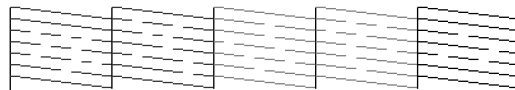

6. If there are no gaps, the print head is clean and you can continue printing.

If there are gaps or the pattern is faint, clean the print head.

**Parent topic:** [Print Head Maintenance](#)

**Related references**

[Setup Menu Settings](#)

[Maintenance Menu Settings](#)

**Related tasks**

[Loading Media](#)

[Viewing and Changing Media Settings](#)

[Cleaning the Print Head](#)

## Cleaning the Print Head

If printouts are faint or have gaps, you should clean the print head to clear the clogged nozzles. Clean the print head only if print quality declines or image colors are incorrect.

**Note:** You can also set up the product to automatically clean the print head at selected intervals using the **Periodical Cleaning** and **Cleaning Cycle** settings in the **Setup** menu.

You can select from three levels of head cleaning:

- **Light:** Use this cleaning level first.
- **Medium:** Use this cleaning level if you cannot clear the clogged nozzles after cleaning with the light level.
- **Heavy:** Use this cleaning level if you cannot clear the clogged nozzles after cleaning with the medium level.

1. Press the **A•A** maintenance button on the control panel.  
You see the **Maintenance** menu.
2. Press the up or down arrow button to select **Head Cleaning** and press the **OK** button.
3. Press the up or down arrow button to choose one of the following cleaning options:
  - **All Nozzles:** Select this option when you see faint printing or gaps in all rows of nozzles in the check pattern. Go to step 5.
  - **Selected Nozzles:** Select this option when you see faint printing or gaps in only certain rows of nozzles in the check pattern. You can select to clean multiple nozzle rows, if necessary.
4. To select the nozzle rows for cleaning, press the up or down arrow button to highlight the row number and press the **OK** button. Repeat for each row you want to clean. When you finish, select **Proceed** and press the **OK** button.

5. Press the up or down arrow button to select the cleaning level and press the **OK** button.  
Print head cleaning starts. When it is complete, the menu closes.
6. Print a nozzle check pattern or check your printout to confirm that the nozzles are cleared.

**Parent topic:** [Print Head Maintenance](#)

**Related references**

[Setup Menu Settings](#)

**Related tasks**

[Checking for Clogged Print Head Nozzles](#)

## Aligning the Print Head

If your printouts are grainy or blurry, you need to align the print head. The thickness of your print media determines the alignment options you select. You can store separate alignment values for each type of media you use for quick selection.

Before aligning the print head, make sure you have correctly loaded the media you plan to print on. Also check that the print head nozzles are not clogged.

1. On the product control panel, press the left or right arrow button to select the  tab and press the **OK** button.

The Maintenance menu appears.

2. Press the up or down arrow button to select **Head Alignment** and press the **OK** button.
3. Press the up or down arrow button to select one of these adjustment methods and press the **OK** button:
  - If you are printing bidirectionally on your media, select the **Manual(Bi-D)** setting. If the print quality has not improved, repeat the steps here and select the **Manual(Uni-D)** setting.
  - If you are printing unidirectionally on your media, select the **Manual(Uni-D)** setting.

Your product prints an alignment test pattern.

4. Examine the alignment test pattern to select the pattern number with the least visible white lines, as in pattern 3 shown here.

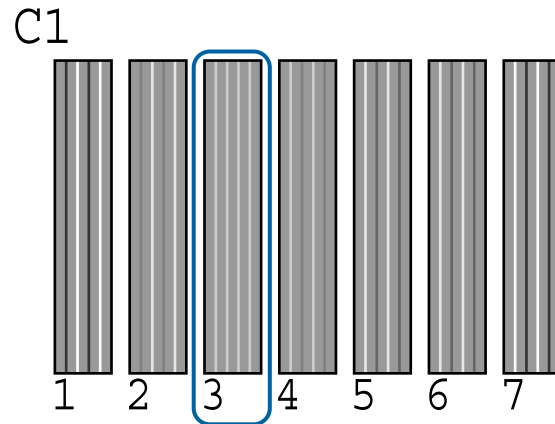

5. If the product control panel displays **C1**, press the up or down arrow button to select the number of the best pattern in C1 and press the **OK** button. Repeat this step for all the color patterns.

After you select the final color pattern number, the control panel returns to its ready status.

**Parent topic:** [Print Head Maintenance](#)

**Related references**

[Maintenance Menu Settings](#)

**Related tasks**

[Loading Media](#)

[Checking for Clogged Print Head Nozzles](#)

## Performing Head Maintenance

If ink smears onto your printed media even after cleaning the print head, you should perform head maintenance to clean inside the product near the print head.

Use the head maintenance kit that came with your product to perform head maintenance.

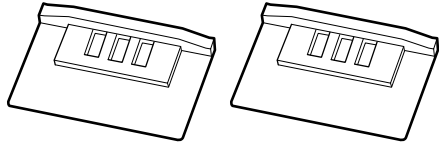

1. Remove any paper loaded in the product.
2. Press the left or right arrow on the product control panel to highlight the  tab and press the **OK** button.

You see the **Maintenance** menu on the product control panel screen.

3. Select **Head Maintenance** and press the **OK** button.

You see a message asking you to prepare the head maintenance kit.

4. Press the **OK** button.

The product moves the print head out of the way.

5. Peel the backing off of the pads in the head maintenance kit.

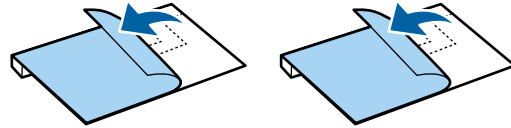

6. Open the printer cover.



7. Place the pads on the platen on both sides of the print head (a).

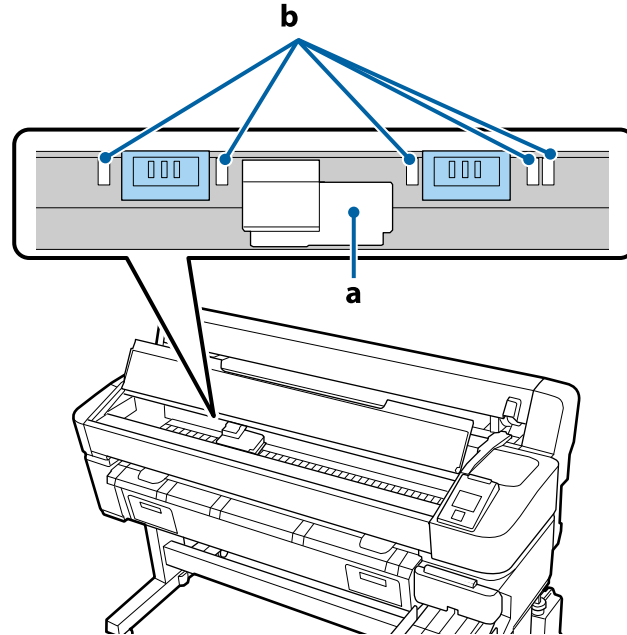

**Caution:** Make sure the pads do not cover the ink absorbing areas (b) on the platen so the pads do not stick to them. Do not move the print head by hand; this can damage your product.

8. Press the edge of each pad against the rollers as shown.

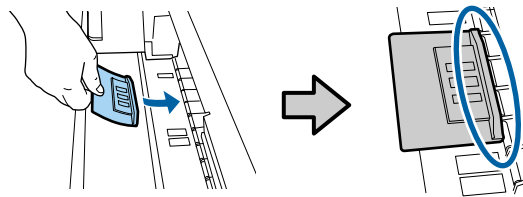

**Note:** Make sure there are no gaps between the pads and the rollers or head maintenance will not be performed properly.

9. Rub the areas shown here to secure the pads to the platen.

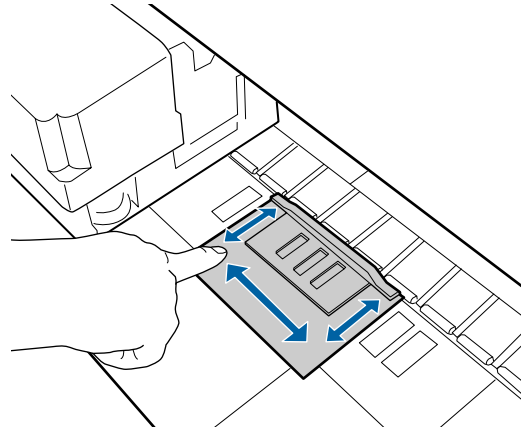

**Caution:** Do not press too hard on the pad or you could damage the platen.

10. Close the printer cover.

**Note:** Do not open the printer cover during head maintenance or the procedure will stop.

11. Press the **OK** button.

The head maintenance procedure begins.

12. Follow the instructions on the product control panel screen to open the printer cover and carefully remove the pads when head maintenance finishes.

**Note:** Do not reuse the pads.

13. Close the printer cover and press the **OK** button to clean the print head.

**Parent topic:** [Print Head Maintenance](#)

#### **Related references**

[Maintenance Precautions](#)

#### **Related tasks**

[Removing Media](#)

## Replacing the Waste Ink Bottle

When you see one of these messages on the product control panel screen, you need to replace the waste ink bottle:

- **Prepare empty waste ink bottle**
- **Replace waste ink bottle and press OK**

Wait until the product is not printing or cleaning the print head before replacing the waste ink bottle.

**Caution:** Replacing the waste ink bottle during printing or cleaning could cause waste ink to leak. When replacing the waste ink bottle, always wear the gloves included in the maintenance kit. Leave the waste ink in the bottle for disposal and do not transfer it to another container.

1. Raise the stopper on the waste ink bottle.

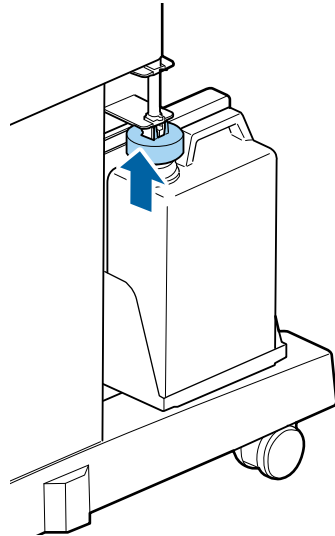

2. Lift up the waste ink bottle and remove it from the holder as shown here.

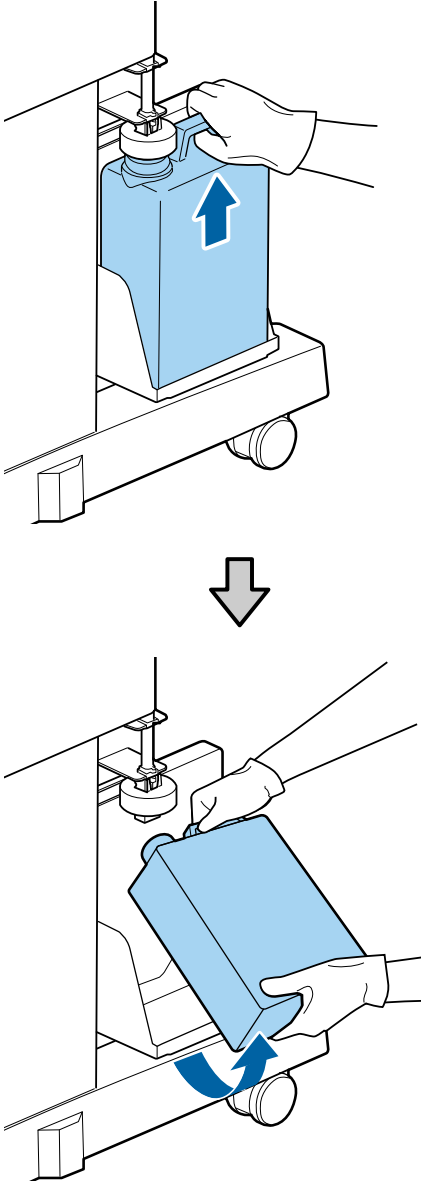

3. Put the inner seal and cap on the used waste ink bottle.
4. Insert the waste ink tube into the new waste ink bottle and place the bottle in the holder.

**Note:** Be sure the waste ink tube is inserted in the waste ink bottle or waste ink could spill onto your product.

5. Lower the stopper onto the waste ink bottle and make sure it firmly seals to the mouth of the bottle.

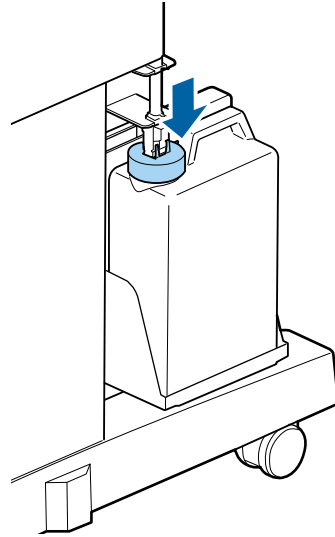

**Note:** If the stopper does not firmly seal, waste ink could spill onto your product.

6. Press the **OK** button on the product control panel.
7. Press the **OK** button again to reset the waste ink counter.

**Caution:** Waste ink is classified as industrial waste. Dispose of waste ink according to your local laws and regulations such as entrusting it to an industrial waste disposal company. When handing over the waste ink to the industrial waste disposal company, make sure you include the Safety Data Sheet (SDS) found on Epson's support website.

**Note:** If you replaced the waste ink bottle before the replacement message appeared on the control panel, press the  maintenance button and select **Waste Ink Counter** to clear the waste ink counter.

**Parent topic:** [Maintenance](#)

**Related references**

[Maintenance Precautions](#)

[Maintenance Menu Settings](#)

## Replacing the Cutter

If the cutter stops cutting paper cleanly, it is time to replace the cutter.

Make sure you have a Phillips-head screwdriver before you begin.

1. Remove any paper loaded in the product.
2. Press the left or right arrow on the product control panel to highlight the  tab and press the **OK** button.

The Maintenance menu appears.

3. Press the up or down arrow button to select **Cutter Maintenance** and press the **OK** button.
4. Press the up or down arrow button to select **Replace Cutter** and press the **OK** button.

The cutter moves into replacement position.

5. Using a Phillips-head screwdriver, loosen the screw holding the cutter in place and carefully pull the cutter straight out.

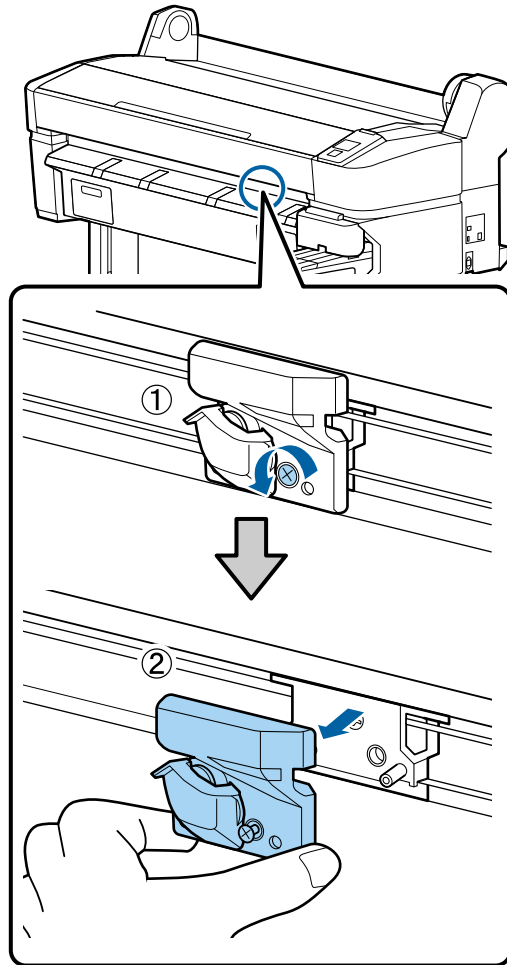

**Warning:** Keep the cutter out of the reach of children. The blade is sharp and can cause injury.

6. Align the holes in the new cutter with the pins on the product. Then fully tighten the screw to secure the cutter.

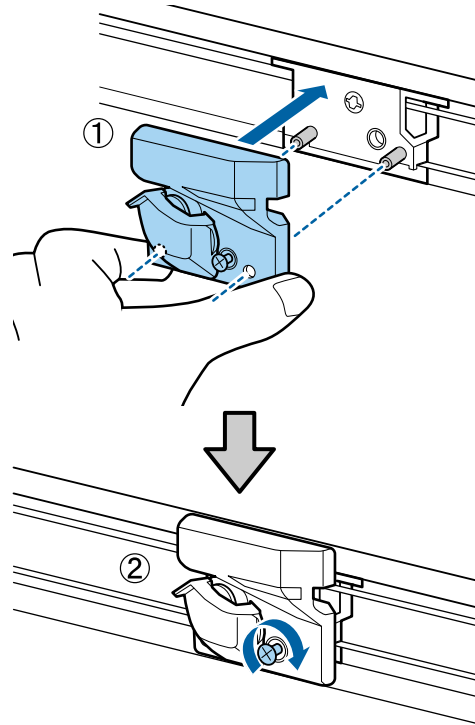

**Note:** Tighten the cutter screw securely so the cutter does not shift position.

7. Press the **OK** button.

The cutter returns to its original position and the product is ready to print.

**Parent topic:** [Maintenance](#)

**Related references**

[Consumables and Replacement Parts](#)

[Maintenance Menu Settings](#)

**Related tasks**

[Cutting Media](#)



## Removing Media

---

## Moving or Transporting the Product

When moving the product, see these sections to prepare and move the product, and set it back up after moving it.

If you need to transport the product a long distance, contact Epson support.

[Prepare to Move the Product](#)

[Setting Up the Product After Moving](#)

### Prepare to Move the Product

Do the following before moving the product:

1. Remove any loaded media.
2. Turn off the product.
3. Remove the waste ink bottle.
4. Remove all cables.
5. Release the locks on the product stand.

**Caution:** Roll the product for only a short distance over a level floor. Do not tilt the product more than 10° in any direction or the product may fall over.

**Parent topic:** [Moving or Transporting the Product](#)

#### Related tasks

[Removing Media](#)

[Replacing the Waste Ink Bottle](#)

### Setting Up the Product After Moving

Follow these steps to set up the product after moving it.

1. Verify that the location is suitable for installation.
2. Install the waste ink bottle.
3. Connect the power cable to an electrical outlet and turn on the printer.
4. Load media in the product.
5. Perform a nozzle check and confirm that there are no clogged nozzles.

6. Align the print head and check the print quality.

**Parent topic:** [Moving or Transporting the Product](#)

**Related tasks**

[Replacing the Waste Ink Bottle](#)

[Loading Media](#)

[Checking for Clogged Print Head Nozzles](#)

[Cleaning the Print Head](#)

---

# Solving Problems

Check these sections for solutions to problems you may have using your product.

[Product Status Messages](#)

[Solving Printer Problems](#)

[Solving Printing Problems](#)

[Solving Print Quality Problems](#)

[Where to Get Help](#)

## Product Status Messages









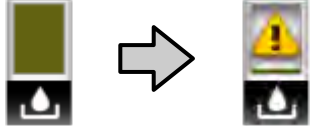

You can often diagnose problems with your product by checking the messages or icons on its LCD screen.

### Error Messages

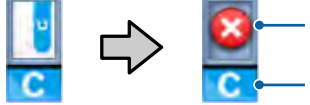
LCD screen message	Solution
Prepare empty waste ink bottle.	The waste ink bottle is almost full. Make sure you have a replacement waste ink bottle handy.
Chip Unit Error Chip unit not recognized. Reattach or replace.	Remove and reinstall the chip unit. If the error recurs, replace the chip unit with a new one. Condensation may have formed inside the ink tank. Make sure the ink is at room temperature for at least four hours.
Chip Unit Error Chip unit not recognized. Refill after matching ink pack with label?	Use only chip units from genuine Epson ink packs specified for this product.
Check Ink Levels	The chip unit is nearing the end of its service life. Make sure you have a replacement ink pack in the correct color handy. Check the remaining ink in the ink tank using the scale on the ink pack and, if necessary, refill the ink.

LCD screen message	Solution
Command Error Check print settings on RIP.	Press the <b>II</b>  pause/cancel button and select <b>Job Cancel</b> . Make sure the installed RIP software is compatible with the product.
F/W Install Error Firmware update failed. Restart the printer.	Turn off the product, wait a few minutes, and turn it on again. Then reinstall the firmware again. If this message persists, contact Epson for support.
Paper Cut Error Remove uncut paper.	Press the <b>OK</b> button, pull out the paper, and cut the media using scissors or a third-party cutting tool.
Paper Size Error Loaded paper is not supported size.	Press the <b>OK</b> button and remove the currently loaded media. Be sure the media is at least 10 inches (254 mm) wide. If this message appears even when the media is the correct width, turn off the <b>Paper Size Check</b> setting and try printing again.
Maintenance Request Replace Part Soon/Replace Part Now XXXXXXXXXX	The product part indicated is nearing or at the end of its service life. Contact Epson for support and provide them with the service code shown on the LCD screen. You must replace the part before printing again. If you continue to print, a call for service occurs.
Call For Service XXX Error XXX Power off and then on. If this doesn't work, note the code and call for service.	A call for service occurs when: <ul style="list-style-type: none"> <li>• The power cable is not connected securely</li> <li>• An error occurs that cannot be cleared</li> </ul> When a call for service has occurred, the printer automatically stops printing. Turn off the printer, disconnect the power cable from both the outlet and the printer, and then reconnect them. Turn the printer on and off several times. If the same call for service is displayed on the LCD screen, contact Epson for support and provide them with the service code shown on the LCD screen.

### Status Icons

Icons	Description
<p data-bbox="474 188 772 217">Waste ink bottle status</p> 	<p data-bbox="806 188 1451 217">The waste ink bottle status is indicated as follows:</p>  The height of the indicator corresponds to the remaining capacity.  The waste ink bottle is almost full. Make sure you have a new waste ink bottle ready.  The waste ink bottle is full. Replace the waste ink bottle with a new one.
<p data-bbox="474 615 680 644">Chip unit status</p> 	<p data-bbox="806 615 1713 644">The chip unit status (1) is indicated as follows (2: color of affected ink):</p>  Ready to print.  Check the ink level in the ink tank, and replace the chip unit and refill the ink. The icon flashes when the ink tank is close to being empty.  Check the message on the LCD screen.  An error has occurred. Check the message on the screen, and clear the error.  The chip unit is incompatible or could not be recognized by the product, or the slider is unlocked. Check the slider and replace the chip unit, if necessary.

Parent topic: [Solving Problems](#)

**Related references**

[Setup Menu Settings](#)  
[Where to Get Help](#)

**Related tasks**

[Replacing the Waste Ink Bottle](#)  
[Replacing the Chip Unit and Refilling Ink](#)  
[Cutting Media](#)

**Related topics**

[Replacing the Ink and Chip Unit](#)

## Solving Printer Problems

Check these sections if you have problems operating your product.

[Printer Does Not Turn On](#)  
[Product Turns Off Automatically](#)  
[LCD Screen Shuts Off](#)  
[Forgot the Administrator Password](#)  
[Red Light Shines Inside the Printer](#)

**Parent topic:** [Solving Problems](#)

### Printer Does Not Turn On

If the printer does not turn on, try these solutions:

- Make sure the power cable is securely connected.
- Make sure the power outlet works by connecting the power cable for another electronic device.

**Parent topic:** [Solving Printer Problems](#)

### Product Turns Off Automatically

If your product turns off automatically, it may be in power off mode. Turn off or adjust the **Power Off Timer** setting as necessary.

**Parent topic:** [Solving Printer Problems](#)

**Related references**

[Setup Menu Settings](#)

## LCD Screen Shuts Off

If the LCD screen shuts off intermittently, the printer may be in Sleep Mode. Try these solutions:

- Press the  power button to exit sleep mode. You can adjust the delay time before the product enters sleep mode in the Power Settings menu.

**Parent topic:** [Solving Printer Problems](#)

### Related references

[Setup Menu Settings](#)

## Forgot the Administrator Password

If you forgot the administrator password you created during network setup, contact Epson for support.

**Parent topic:** [Solving Printer Problems](#)

## Red Light Shines Inside the Printer

The red light always shines inside the printer. This is normal.

**Parent topic:** [Solving Printer Problems](#)

## Solving Printing Problems

Check these sections if you have problems printing with your product.

[Nothing Prints](#)

[Cannot Print Over a Network](#)

[Print Head Moves But Nothing Prints](#)

[Removing Jammed Media](#)

[Media Does Not Feed or Eject Correctly](#)

[Media Does Not Cut Cleanly](#)

**Parent topic:** [Solving Problems](#)

## Nothing Prints

If you have sent a print job and nothing prints, try these solutions:

- Make sure your printer is turned on.
- Make sure any interface cables are connected securely at both ends. If you have a spare cable, try connecting with the spare cable.



- Check the model and specifications of the interface cable to see if the cable is appropriate for your computer and printer.
- If you connected your printer to a USB hub, make sure it is a first-tier hub. If it still does not print, connect your printer directly to your computer instead of the hub.
- Make sure the USB hub is recognized correctly on the computer. Disconnect all USB hubs from the computer and connect the printer directly to the computer's USB port.
- Make sure the USB cable length does not exceed 10 feet (3 m).

**Parent topic:** [Solving Printing Problems](#)

## Cannot Print Over a Network

If you cannot print over a network, try these solutions:

- Make sure that your printer is turned on.
- If you are using TCP/IP, make sure the printer's IP address is set correctly for your network. If your network does not assign IP addresses using DHCP, set the IP address manually.
- Check your wired LAN router or access point to see if the LED for the port to which your printer is connected is on or flashing. If the link LED is off, try the following:
  - Make sure the Ethernet cable is securely connected to your printer and to your router, access point, switch, or hub.
  - Try connecting your printer to a different port or a different router, access point, switch, or hub.
  - Try connecting with a different Ethernet cable.
  - Try printing to your printer from another computer on the network.

**Parent topic:** [Solving Printing Problems](#)

### Related references

[Setup Menu Settings](#)

## Print Head Moves But Nothing Prints

If the print head is moving and nothing prints, try these solutions:

- Print a nozzle check pattern. If the pattern does not print correctly, clean the print head again. (If the printer has not been used for a long time the nozzles may be clogged.)
- If you see the message **Motor Self Adjustment** on the product control panel screen, the printer is adjusting its internal motor. Wait a few moments for the message to disappear and do not turn off the printer.

**Parent topic:** [Solving Printing Problems](#)

**Related tasks**

[Checking for Clogged Print Head Nozzles](#)

[Cleaning the Print Head](#)

## Removing Jammed Media

If media jams in the printer, check the following:

- Make sure the media is not curled, creased, or folded on the leading edge. Do not use media that exhibits these problems.
- Check the media specifications to make sure you can use the media with your printer and your RIP software. Check the RIP software manufacturers media guidelines.

Follow the steps here if media becomes jammed in the product.

1. Turn off the product, wait a moment, and turn it back on.

After a moment, you see a message telling you to open the printer cover on the product control panel screen.

2. Open the printer cover and move the print head away from the jammed paper by hand.

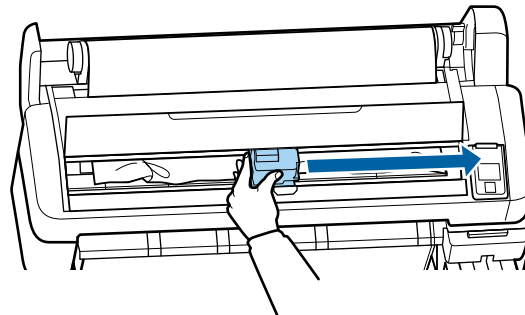

3. Pull the media toward you and cut off any torn or creased media from the roll using scissors or a third-party cutting tool.
4. Manually rewind the media.
5. Close the printer cover and press the **OK** button.
6. Run a nozzle check and, if necessary, clean the print head.

**Parent topic:** [Solving Printing Problems](#)

### **Related tasks**

[Checking for Clogged Print Head Nozzles](#)  
[Cleaning the Print Head](#)

## **Media Does Not Feed or Eject Correctly**

If media does not feed straight or eject from the product correctly, try these solutions:

- Make sure the media is loaded correctly, and is not creased, folded, or jammed in the product.
- Make sure your media is not too thick or thin, and the paper settings match the media. Check the media specifications and your RIP software documentation.
- If you continue to have problems ejecting certain media, check that the **Paper Suction** setting on the product control panel is not too strong.

**Parent topic:** [Solving Printing Problems](#)

### **Related references**

[Paper Menu Settings](#)  
[Paper Specifications](#)

### **Related tasks**

[Loading Media](#)

## **Media Does Not Cut Cleanly**

If the built-in cutter does not cleanly cut your media, replace the cutter.

**Parent topic:** [Solving Printing Problems](#)

### **Related tasks**

[Cutting Media](#)  
[Replacing the Cutter](#)

## **Solving Print Quality Problems**

Check these sections if you have problems with print quality.

[Nozzle Check Pattern Prints Incorrectly](#)  
[Overall Print Quality Is Poor](#)  
[Printed Media is Stained or Marred](#)  
[Image is not Positioned Correctly on the Media](#)

**Parent topic:** [Solving Problems](#)

## Nozzle Check Pattern Prints Incorrectly

If the nozzle check pattern does not print correctly, try these solutions:

- Clean the print head and print the check pattern again.
- If the printer has not been used for a long time, nozzles may be dried and clogged. Turn the printer on at least once every two weeks to prevent the nozzles from clogging.
- Lint may have adhered to the platen near the print head. Clean the area using the maintenance kit.
- If nozzles are still clogged after head cleaning at the strongest level, leave the product turned off overnight and check the nozzles again. If you still cannot clear the nozzles, contact Epson support.

**Parent topic:** [Solving Print Quality Problems](#)

### Related tasks

[Checking for Clogged Print Head Nozzles](#)

[Cleaning the Print Head](#)

[Performing Head Maintenance](#)

## Overall Print Quality Is Poor

If you notice that your print quality is uneven, too light, too dark, or there are vertical or horizontal lines in the print (banding), try these solutions:

- Run a nozzle check to see if any of the print head nozzles are clogged. Then clean the print head, if necessary.
- Align the print head.
- Use genuine Epson ink packs and make sure the ink packs have not expired.
- Make sure the media settings in your RIP software or product control panel match the media you loaded.
- If you are comparing the print result with the image on your computer screen, the colors may not match. Since monitors and printers produce colors differently, printed colors and screen colors do not always look the same.
- Make sure that the printer cover is closed. Do not open any printer covers during printing. This can cause the print head to stop abruptly, resulting in uneven color.

**Parent topic:** [Solving Print Quality Problems](#)

### Related references

[Consumables and Replacement Parts](#)

### **Related tasks**

[Checking for Clogged Print Head Nozzles](#)

[Cleaning the Print Head](#)

[Aligning the Print Head](#)

[Viewing and Changing Media Settings](#)

## **Printed Media is Stained or Marred**

If the printed media is stained or the surface is marred, try these solutions:

- Make sure the media is not too thick or thin. Check that it meets the media specifications for your product and RIP software.
- Check that the media is not creased or folded, causing it to contact the print head. If necessary, load new media.
- Adjust the **Platen Gap** setting on the product control panel to prevent the print head from striking the media as you print.
- If the edge of the media is marred, set the **Roll Paper Margin** setting on the product control panel to the **Top35mm/Bottom15mm** setting. If the bottom edge of the media is marred, select a setting with a 150 mm bottom margin.
- Feed and eject paper to clean the rollers inside the product.

**Parent topic:** [Solving Print Quality Problems](#)

### **Related references**

[Paper Menu Settings](#)

[Setup Menu Settings](#)

[Paper Specifications](#)

### **Related tasks**

[Loading Media](#)

[Cleaning the Product](#)

## **Image is not Positioned Correctly on the Media**

If the printed image is not positioned correctly on your media, try these solutions:

- Make sure you loaded the media correctly and selected the correct margin settings for it on the product control panel.
- Make sure you specified the correct print area in your printing software.

- Turn on the **Paper Skew Check** and **Paper Size Check** settings on the product control panel to prevent your image from printing outside the printable area.

**Parent topic:** [Solving Print Quality Problems](#)

**Related references**

[Printable Area and Media Size Checking](#)

[Setup Menu Settings](#)

**Related tasks**

[Loading Media](#)

## Where to Get Help

Epson provides technical support and information on the installation, configuration, and operation of professional printing products through the Epson Preferred Limited Warranty Plan. Dial (888) 377-6611, 6 AM to 6 PM, Pacific Time, Monday through Friday. Days and hours of support are subject to change without notice.

Before you call, make sure you have your Unit ID number, which is included with the Epson Preferred Limited Warranty Plan information that came with your printer. You'll also need your printer serial number and proof of purchase.

Visit Epson's [U.S. support website](#) or [Canadian website](#) and select your product for solutions to common problems. You can download drivers, firmware, and documentation, get FAQs and troubleshooting advice, or e-mail Epson with your questions.

**Note:** For help using any other software on your system, see the documentation for that software for technical support information.

### **Purchase Supplies and Accessories**

You can purchase genuine Epson ink packs, paper, and accessories from an Epson authorized reseller. To find the nearest reseller, call 800-GO-EPSON (800-463-7766).

**Parent topic:** [Solving Problems](#)

---

# Technical Specifications

These sections list the technical specifications for your product.

**Note:** Epson offers a recycling program for end of life products. Please go to [this site](#) for information on how to return your products for proper disposal.

[Windows System Requirements](#)

[Printing Specifications](#)

[Electrical Specifications](#)

[Environmental Specifications](#)

[Dimension Specifications](#)

[Interface Specifications](#)

[Ink Pack Specifications](#)

[Paper Specifications](#)

[Safety and Approvals Specifications](#)

## Windows System Requirements

To use your product and its software, your computer should meet these requirements.

Microsoft Windows OS version (32- and 64-bit compatible)	Windows 7, Windows 8.x
CPU	Core 2 Duo 2.0 GHZ or better
Memory	1GB or more
Hard disk space available	32GB or more
Interface	Two High-Speed USB ports compatible with USB 2.0 Specification Rear port: for computer connection Front port: for external USB device connection
Display resolution	XGA (1024 × 768) or higher

**Note:** Visit Epson's support website at [epson.com/support](http://epson.com/support) (U.S.) or [epson.ca/support](http://epson.ca/support) (Canada) for the latest in compatibility and drivers for your product.

Parent topic: [Technical Specifications](#)

## Printing Specifications

<b>Printing method</b>	On-demand ink jet
<b>Nozzle configuration</b>	360 nozzles × 2 × 4 colors
<b>Resolution</b>	720 × 1440 dpi maximum
<b>Control code</b>	ESC/P raster (undisclosed command)
<b>Media feed method</b>	Friction feed
<b>Built-in memory</b>	Main memory: 512MB Network: 128MB

Parent topic: [Technical Specifications](#)

## Electrical Specifications

<b>Power supply rating</b>	100 to 240 V
<b>Rated frequency range</b>	50/60 Hz
<b>Rated current</b>	1.0 to 0.5 A
<b>Power consumption</b>	Printing: approximately 65 W (ISO/IEC24712) Sleep mode: 3.0 W or less Power off mode: 0.4 W or less

Parent topic: [Technical Specifications](#)



## Environmental Specifications

<b>Temperature</b>	Operating: 59 to 95 °F (15 to 35 °C) ; 59 to 77 °F (15 to 25 °C) recommended Storage (before unpacking): –4 to 140 °F (–20 to 60 °C), no more than 120 hours at 140 °F (60 °C), within a month at 104 °F (40 °C) Storage (after unpacking): –4 to 104 °F (–20 to 40 °C), within a month at 104 °F (40 °C)
<b>Humidity</b> (non-condensing)	Operating: 20 to 80% RH; 40 to 60% RH recommended Storage (before and after unpacking): 5 to 85% RH

Parent topic: [Technical Specifications](#)

## Dimension Specifications

<b>Height</b>	44.4 inches (1128 mm)
<b>Width</b>	63.3 inches (1608 mm)
<b>Depth</b>	36.0 inches (914 mm)
<b>Weight</b> (without ink)	207.2 lb (94 kg)

Parent topic: [Technical Specifications](#)

## Interface Specifications

<b>USB Interface</b>	Hi-Speed USB-Compatible with the Universal Serial Bus Specifications Revision 2.0
<b>Network Interface</b>	100Base-TX/1000Base-T (requires a shielded twisted pair cable, category 5 or higher)

Parent topic: [Technical Specifications](#)

## Ink Pack Specifications

<b>Sublimation transfer ink color</b>	High Density Black, Cyan, Magenta, Yellow
<b>Ink life</b>	Do not use if the date on the package has expired
<b>Print quality guarantee</b>	25 days (from the day the ink tank was refilled from the ink pack)
<b>Temperature</b>	In transit (unopened): –4 to 140 °F (–20 to 60 °C) 1 month at 104 °F (40 °C) 8 hours at 140 °F (60 °C) In storage (opened): 41 to 95 °F (5 to 35 °C); 59 to 77 °F (15 to 25 °C) recommended
<b>Capacity</b>	1000 ml

**Parent topic:** [Technical Specifications](#)

**Related references**

[Consumables and Replacement Parts](#)

## Paper Specifications

Print quality is greatly affected by the type and quality of paper used. Always test a sample of paper before purchasing large quantities or printing large jobs.

**Note:** Do not use paper that is wrinkled, scratched, torn, or dirty.

<b>Roll core size</b>	2 or 3 inches
<b>Roll outer diameter</b>	Up to 5.9 inches (150 mm)
<b>Paper width</b>	10 to 44 inches (254 to 1118 mm)
<b>Paper thickness</b>	0.003 to 0.02 inch (0.08 to 0.5 mm)

**Parent topic:** [Technical Specifications](#)

## Safety and Approvals Specifications

### United States

Safety: UL60950-1

EMC: FCC part 15 Subpart B class A

### Canada

Safety: CAN/CSA C22.2 No. 60950-1

EMC: CAN/CSA-CEI/IEC CISPR 22 Class A

Parent topic: [Technical Specifications](#)

---

## Notices

Check these sections for important notices about your product.

**Note:** Epson offers a recycling program for end of life products. Please go to [this site](#) for information on how to return your products for proper disposal.

[Important Safety Instructions](#)

[FCC Compliance Statement](#)

[Software License Terms](#)

[Trademarks](#)

[Copyright Notice](#)

## Important Safety Instructions

Before using your Epson product, read and follow these safety instructions.

[General Product Safety Instructions](#)

[Ink Pack Safety Instructions](#)

**Parent topic:** [Notices](#)

## General Product Safety Instructions

- Be sure to follow all warnings and instructions marked on the product.
- Use only the type of power source indicated on the product's label.
- Use only the power cord that comes with the product. Use of another cord may cause fires or shock. Do not use the cord with any other equipment.
- Place the product near a wall outlet where the plug can be easily unplugged.
- Connect your product to a properly grounded power outlet. Avoid plugging the product into an outlet on the same circuit as a photo copier or air control system that regularly switches on and off, or on an outlet controlled by a wall switch or timer.
- Do not let the power cord become damaged or frayed. Place it to avoid abrasions, cuts, fraying, crimping, and kinking. Do not place objects on top of it and do not allow it to be stepped on or run over. Be careful to keep the cord straight at each end.
- If you use an extension cord with the product, make sure the total ampere rating of the devices plugged into the extension cord does not exceed the cord's ampere rating. Also, make sure the total

ampere rating of all devices plugged into the wall outlet does not exceed the wall outlet's ampere rating.

- If damage occurs to the plug, replace the cord set or consult a qualified electrician. If there are fuses in the plug, make sure you replace them with fuses of the correct size and rating.
- Always turn off the product using the power button, and wait until the power light stops flashing before unplugging the product or cutting off power to the electrical outlet.
- If you will not be using the product for a long period, unplug the power cord from the electrical outlet.
- Place the product on a flat, stable surface that extends beyond its base in all directions. It will not operate properly if it is tilted or at an angle.
- Avoid locations that are subject to rapid changes in heat or humidity, shocks or vibrations, or dust.
- Do not place or store the product outdoors.
- Do not place the product near excessive heat sources or in direct sunlight.
- Leave enough room around the product for sufficient ventilation. Do not block or cover openings in the cabinet or insert objects through the slots.
- Keep the product away from potential sources of electromagnetic interference, such as loudspeakers or the base units of cordless telephones.
- When connecting the product to a computer or other device with a cable, ensure the correct orientation of the connectors. Each connector has only one correct orientation. Inserting a connector in the wrong orientation may damage both devices connected by the cable.
- Do not spill liquid on the product or use the product with wet hands.
- Do not use aerosol products that contain flammable gases inside or around the product. Doing so may cause fire.
- Except as specifically explained in your documentation, do not attempt to service the product yourself.
- Unplug the product and refer servicing to qualified service personnel under the following conditions: if the power cord or plug is damaged; if liquid has entered the product; if the product has been dropped or the cabinet damaged; if the product does not operate normally or exhibits a distinct change in performance. Adjust only those controls that are covered by the operating instructions.
- When storing or transporting the product, do not tilt it, stand it on its side, or turn it upside down; otherwise ink may leak.

**Note:** The lithium batteries in this product contain Perchlorate Material - special handling may apply. [Click here](#) for details.

**Parent topic:** [Important Safety Instructions](#)

## Ink Pack Safety Instructions

- Keep ink packs out of the reach of children and do not drink the ink.
- Wear protective eyewear, gloves, and a mask when performing maintenance.
- Should ink touch your skin or enter your eyes or mouth, immediately take the following actions:
  - If fluid touches your skin, wash it off immediately with large volumes of soapy water. Consult a physician if the skin appears irritated or discolored.
  - If fluid gets in your eyes, rinse immediately with water. Failure to observe this precaution could result in bloodshot eyes or mild inflammation. If problems persist, consult with a physician.
  - If swallowed, do not induce vomiting and consult with a physician as soon as possible.
  - If fluid gets in your mouth, consult a physician as soon as possible.

Parent topic: [Important Safety Instructions](#)

## FCC Compliance Statement

### For United States Users

This equipment has been tested and found to comply with the limits for a Class A digital device, pursuant to Part 15 of the FCC Rules. These limits are designed to provide reasonable protection against harmful interference when the equipment is operated in a commercial environment. This equipment generates, uses, and can radiate radio frequency energy and, if not installed and used in accordance with the instruction manual, may cause harmful interference to radio communications. Operation of this equipment in a residential area is likely to cause harmful interference, in which case the user will be required to correct the interference at his own expense.

This device complies with Part 15 of the FCC Rules. Operation is subject to the following two conditions:

1. this device may not cause harmful interference, and
2. this device must accept any interference received, including interference that may cause undesired operation.

### WARNING

The connection of a non-shielded equipment interface cable to this equipment will invalidate the FCC Certification of this device and may cause interference levels which exceed the limits established by the FCC for this equipment. It is the responsibility of the user to obtain and use a shielded equipment interface cable with this device. If this equipment has more than one interface connector, do not leave cables connected to unused interfaces. Changes or modifications not expressly approved by the manufacturer could void the user's authority to operate the equipment.

### **For Canadian Users**

This Class A digital apparatus complies with Canadian ICES-003.

*Cet appareil numérique de la classe A est conforme à la norme NMB-003 du Canada.*

### **WARNING**

This is a Class A product. In a domestic environment this product may cause radio interference, in which case the user may be required to take adequate measures.

**Parent topic:** [Notices](#)

## **Software License Terms**

### **Bonjour**

This printer product includes the open source software programs which apply the Apple Public Source License Version 1.2 or its latest version ("Bonjour Programs").

We provide the source code of the Bonjour Programs pursuant to the Apple Public Source License Version 1.2 or its latest version until five (5) years after the discontinuation of same model of this printer product. If you desire to receive the source code of the Bonjour Programs, contact Epson support.

You can redistribute Bonjour Programs and/or modify it under the terms of the Apple Public Source License Version 1.2 or its latest version.

These Bonjour Programs are WITHOUT ANY WARRANTY; without even the implied warranty of MERCHANTABILITY AND FITNESS FOR A PARTICULAR PURPOSE.

The Apple Public Source License Version 1.2 is as follows. You also can see the Apple Public Source License Version 1.2 at <http://www.opensource.apple.com/apsl/>.

### **APPLE PUBLIC SOURCE LICENSE**

Version 2.0 - August 6, 2003

1. General; Definitions. This License applies to any program or other work which Apple Computer, Inc. ("Apple") makes publicly available and which contains a notice placed by Apple identifying such program or work as "Original Code" and stating that it is subject to the terms of this Apple Public Source License version 2.0 ("License"). As used in this License:

1.1 "Applicable Patent Rights" mean: (a) in the case where Apple is the grantor of rights, (i) claims of patents that are now or hereafter acquired, owned by or assigned to Apple and (ii) that cover subject matter contained in the Original Code, but only to the extent necessary to use, reproduce and/or distribute the Original Code without infringement; and (b) in the case where You are the grantor of rights, (i) claims of patents that are now or hereafter acquired, owned by or assigned to You and (ii) that cover subject matter in Your Modifications, taken alone or in combination with Original Code.

1.2 "Contributor" means any person or entity that creates or contributes to the creation of Modifications.

1.3 "Covered Code" means the Original Code, Modifications, the combination of Original Code and any Modifications, and/or any respective portions thereof.

1.4 "Externally Deploy" means:(a) to sublicense, distribute or otherwise make Covered Code available, directly or indirectly, to anyone other than You; and/or (b) to use Covered Code, alone or as part of a Larger Work, in any way to provide a service, including but not limited to delivery of content, through electronic communication with a client other than You.

1.5 "Larger Work" means a work which combines Covered Code or portions thereof with code not governed by the terms of this License.

1.6 "Modifications" mean any addition to, deletion from, and/or change to, the substance and/or structure of the Original Code, any previous Modifications, the combination of Original Code and any previous Modifications, and/or any respective portions thereof. When code is released as a series of files, a Modification is:(a) any addition to or deletion from the contents of a file containing Covered Code; and/or (b) any new file or other representation of computer program statements that contains any part of Covered Code.

1.7 "Original Code" means (a) the Source Code of a program or other work as originally made available by Apple under this License, including the Source Code of any updates or upgrades to such programs or works made available by Apple under this License, and that has been expressly identified by Apple as such in the header file(s) of such work; and (b) the object code compiled from such Source Code and originally made available by Apple under this License.

1.8 "Source Code" means the human readable form of a program or other work that is suitable for making modifications to it, including all modules it contains, plus any associated interface definition files, scripts used to control compilation and installation of an executable (object code).

1.9 "You" or "Your" means an individual or a legal entity exercising rights under this License. For legal entities, "You" or "Your" includes any entity which controls, is controlled by, or is under common control with, You, where "control" means (a) the power, direct or indirect, to cause the direction or management of such entity, whether by contract or otherwise, or (b) ownership of fifty percent (50%) or more of the outstanding shares or beneficial ownership of such entity.

2. Permitted Uses; Conditions & Restrictions. Subject to the terms and conditions of this License, Apple hereby grants You, effective on the date You accept this License and download the Original Code, a world-wide, royalty-free, non-exclusive license, to the extent of Apple's Applicable Patent Rights and copyrights covering the Original Code, to do the following:

2.1 Unmodified Code. You may use, reproduce, display, perform, internally distribute within Your organization, and Externally Deploy verbatim, unmodified copies of the Original Code, for commercial or non-commercial purposes, provided that in each instance:



(a) You must retain and reproduce in all copies of Original Code the copyright and other proprietary notices and disclaimers of Apple as they appear in the Original Code, and keep intact all notices in the Original Code that refer to this License; and

(b) You must include a copy of this License with every copy of Source Code of Covered Code and documentation You distribute or Externally Deploy, and You may not offer or impose any terms on such Source Code that alter or restrict this License or the recipients' rights hereunder, except as permitted under Section 6.

2.2 Modified Code. You may modify Covered Code and use, reproduce, display, perform, internally distribute within Your organization, and Externally Deploy Your Modifications and Covered Code, for commercial or non-commercial purposes, provided that in each instance You also meet all of these conditions:

(a) You must satisfy all the conditions of Section 2.1 with respect to the Source Code of the Covered Code;

(b) You must duplicate, to the extent it does not already exist, the notice in Exhibit A in each file of the Source Code of all Your Modifications, and cause the modified files to carry prominent notices stating that You changed the files and the date of any change; and

(c) If You Externally Deploy Your Modifications, You must make Source Code of all Your Externally Deployed Modifications either available to those to whom You have Externally Deployed Your Modifications, or publicly available. Source Code of Your Externally Deployed Modifications must be released under the terms set forth in this License, including the license grants set forth in Section 3 below, for as long as you Externally Deploy the Covered Code or twelve (12) months from the date of initial External Deployment, whichever is longer. You should preferably distribute the Source Code of Your Externally Deployed Modifications electronically (e.g. download from a web site).

2.3 Distribution of Executable Versions. In addition, if You Externally Deploy Covered Code (Original Code and/or Modifications) in object code, executable form only, You must include a prominent notice, in the code itself as well as in related documentation, stating that Source Code of the Covered Code is available under the terms of this License with information on how and where to obtain such Source Code.

2.4 Third Party Rights. You expressly acknowledge and agree that although Apple and each Contributor grants the licenses to their respective portions of the Covered Code set forth herein, no assurances are provided by Apple or any Contributor that the Covered Code does not infringe the patent or other intellectual property rights of any other entity. Apple and each Contributor disclaim any liability to You for claims brought by any other entity based on infringement of intellectual property rights or otherwise. As a condition to exercising the rights and licenses granted hereunder, You hereby assume sole responsibility to secure any other intellectual property rights needed, if any. For example, if a third party patent license is required to allow You to distribute the Covered Code, it is Your responsibility to acquire that license before distributing the Covered Code.

3. Your Grants. In consideration of, and as a condition to, the licenses granted to You under this License, You hereby grant to any person or entity receiving or distributing Covered Code under this License a non-exclusive, royalty-free, perpetual, irrevocable license, under Your Applicable Patent Rights and other intellectual property rights (other than patent) owned or controlled by You, to use, reproduce, display, perform, modify, sublicense, distribute and Externally Deploy Your Modifications of the same scope and extent as Apple's licenses under Sections 2.1 and 2.2 above.

4. Larger Works. You may create a Larger Work by combining Covered Code with other code not governed by the terms of this License and distribute the Larger Work as a single product. In each such instance, You must make sure the requirements of this License are fulfilled for the Covered Code or any portion thereof.

5. Limitations on Patent License. Except as expressly stated in Section 2, no other patent rights, express or implied, are granted by Apple herein. Modifications and/or Larger Works may require additional patent licenses from Apple which Apple may grant in its sole discretion.

6. Additional Terms. You may choose to offer, and to charge a fee for, warranty, support, indemnity or liability obligations and/or other rights consistent with the scope of the license granted herein ("Additional Terms") to one or more recipients of Covered Code. However, You may do so only on Your own behalf and as Your sole responsibility, and not on behalf of Apple or any Contributor. You must obtain the recipient's agreement that any such Additional Terms are offered by You alone, and You hereby agree to indemnify, defend and hold Apple and every Contributor harmless for any liability incurred by or claims asserted against Apple or such Contributor by reason of any such Additional Terms.

7. Versions of the License. Apple may publish revised and/or new versions of this License from time to time. Each version will be given a distinguishing version number. Once Original Code has been published under a particular version of this License, You may continue to use it under the terms of that version. You may also choose to use such Original Code under the terms of any subsequent version of this License published by Apple. No one other than Apple has the right to modify the terms applicable to Covered Code created under this License.

8. NO WARRANTY OR SUPPORT. The Covered Code may contain in whole or in part pre-release, untested, or not fully tested works. The Covered Code may contain errors that could cause failures or loss of data, and may be incomplete or contain inaccuracies. You expressly acknowledge and agree that use of the Covered Code, or any portion thereof, is at Your sole and entire risk. THE COVERED CODE IS PROVIDED "AS IS" AND WITHOUT WARRANTY, UPGRADES OR SUPPORT OF ANY KIND AND APPLE AND APPLE'S LICENSOR(S) (COLLECTIVELY REFERRED TO AS "APPLE" FOR THE PURPOSES OF SECTIONS 8 AND 9) AND ALL CONTRIBUTORS EXPRESSLY DISCLAIM ALL WARRANTIES AND/OR CONDITIONS, EXPRESS OR IMPLIED, INCLUDING, BUT NOT LIMITED TO, THE IMPLIED WARRANTIES AND/OR CONDITIONS OF MERCHANTABILITY, OF SATISFACTORY QUALITY, OF FITNESS FOR A PARTICULAR PURPOSE, OF ACCURACY, OF QUIET ENJOYMENT, AND NONINFRINGEMENT OF THIRD PARTY RIGHTS. APPLE AND EACH CONTRIBUTOR DOES NOT WARRANT AGAINST INTERFERENCE WITH YOUR ENJOYMENT OF THE COVERED CODE, THAT THE FUNCTIONS CONTAINED IN THE COVERED CODE WILL MEET YOUR

REQUIREMENTS, THAT THE OPERATION OF THE COVERED CODE WILL BE UNINTERRUPTED OR ERROR-FREE, OR THAT DEFECTS IN THE COVERED CODE WILL BE CORRECTED. NO ORAL OR WRITTEN INFORMATION OR ADVICE GIVEN BY APPLE, AN APPLE AUTHORIZED REPRESENTATIVE OR ANY CONTRIBUTOR SHALL CREATE A WARRANTY. You acknowledge that the Covered Code is not intended for use in the operation of nuclear facilities, aircraft navigation, communication systems, or air traffic control machines in which case the failure of the Covered Code could lead to death, personal injury, or severe physical or environmental damage.

9. LIMITATION OF LIABILITY. TO THE EXTENT NOT PROHIBITED BY LAW, IN NO EVENT SHALL APPLE OR ANY CONTRIBUTOR BE LIABLE FOR ANY INCIDENTAL, SPECIAL, INDIRECT OR CONSEQUENTIAL DAMAGES ARISING OUT OF OR RELATING TO THIS LICENSE OR YOUR USE OR INABILITY TO USE THE COVERED CODE, OR ANY PORTION THEREOF, WHETHER UNDER A THEORY OF CONTRACT, WARRANTY, TORT (INCLUDING NEGLIGENCE), PRODUCTS LIABILITY OR OTHERWISE, EVEN IF APPLE OR SUCH CONTRIBUTOR HAS BEEN ADVISED OF THE POSSIBILITY OF SUCH DAMAGES AND NOTWITHSTANDING THE FAILURE OF ESSENTIAL PURPOSE OF ANY REMEDY. SOME JURISDICTIONS DO NOT ALLOW THE LIMITATION OF LIABILITY OF INCIDENTAL OR CONSEQUENTIAL DAMAGES, SO THIS LIMITATION MAY NOT APPLY TO YOU. In no event shall Apple's total liability to You for all damages (other than as may be required by applicable law) under this License exceed the amount of fifty dollars (\$50.00).

10. Trademarks. This License does not grant any rights to use the trademarks or trade names "Apple", "Apple Computer", "Mac", "Mac OS", "QuickTime", "QuickTime Streaming Server" or any other trademarks, service marks, logos or trade names belonging to Apple (collectively "Apple Marks") or to any trademark, service mark, logo or trade name belonging to any Contributor. You agree not to use any Apple Marks in or as part of the name of products derived from the Original Code or to endorse or promote products derived from the Original Code other than as expressly permitted by and in strict compliance at all times with Apple's third party trademark usage guidelines which are posted at <http://www.apple.com/legal/guidelinesfor3rdparties.html>.

11. Ownership. Subject to the licenses granted under this License, each Contributor retains all rights, title and interest in and to any Modifications made by such Contributor. Apple retains all rights, title and interest in and to the Original Code and any Modifications made by or on behalf of Apple ("Apple Modifications"), and such Apple Modifications will not be automatically subject to this License. Apple may, at its sole discretion, choose to license such Apple Modifications under this License, or on different terms from those contained in this License or may choose not to license them at all.

12. Termination.

12.1 Termination. This License and the rights granted hereunder will terminate:

(a) automatically without notice from Apple if You fail to comply with any term(s) of this License and fail to cure such breach within 30 days of becoming aware of such breach;

(b) immediately in the event of the circumstances described in Section 13.5(b); or

(c) automatically without notice from Apple if You, at any time during the term of this License, commence an action for patent infringement against Apple; provided that Apple did not first commence an action for patent infringement against You in that instance.

12.2 Effect of Termination. Upon termination, You agree to immediately stop any further use, reproduction, modification, sublicensing and distribution of the Covered Code. All sublicenses to the Covered Code which have been properly granted prior to termination shall survive any termination of this License. Provisions which, by their nature, should remain in effect beyond the termination of this License shall survive, including but not limited to Sections 3, 5, 8, 9, 10, 11, 12.2 and 13. No party will be liable to any other for compensation, indemnity or damages of any sort solely as a result of terminating this License in accordance with its terms, and termination of this License will be without prejudice to any other right or remedy of any party.

### 13. Miscellaneous.

13.1 Government End Users. The Covered Code is a "commercial item" as defined in FAR 2.101. Government software and technical data rights in the Covered Code include only those rights customarily provided to the public as defined in this License. This customary commercial license in technical data and software is provided in accordance with FAR 12.211 (Technical Data) and 12.212 (Computer Software) and, for Department of Defense purchases, DFAR 252.227-7015 (Technical Data - Commercial Items) and 227.7202-3 (Rights in Commercial Computer Software or Computer Software Documentation). Accordingly, all U.S. Government End Users acquire Covered Code with only those rights set forth herein.

13.2 Relationship of Parties. This License will not be construed as creating an agency, partnership, joint venture or any other form of legal association between or among You, Apple or any Contributor, and You will not represent to the contrary, whether expressly, by implication, appearance or otherwise.

13.3 Independent Development. Nothing in this License will impair Apple's right to acquire, license, develop, have others develop for it, market and/or distribute technology or products that perform the same or similar functions as, or otherwise compete with, Modifications, Larger Works, technology or products that You may develop, produce, market or distribute.

13.4 Waiver; Construction. Failure by Apple or any Contributor to enforce any provision of this License will not be deemed a waiver of future enforcement of that or any other provision. Any law or regulation which provides that the language of a contract shall be construed against the drafter will not apply to this License.

13.5 Severability. (a) If for any reason a court of competent jurisdiction finds any provision of this License, or portion thereof, to be unenforceable, that provision of the License will be enforced to the maximum extent permissible so as to effect the economic benefits and intent of the parties, and the remainder of this License will continue in full force and effect. (b) Notwithstanding the foregoing, if applicable law prohibits or restricts You from fully and/or specifically complying with Sections 2 and/or 3 or prevents the enforceability of either of those Sections, this License will immediately terminate and You

must immediately discontinue any use of the Covered Code and destroy all copies of it that are in your possession or control.

13.6 Dispute Resolution. Any litigation or other dispute resolution between You and Apple relating to this License shall take place in the Northern District of California, and You and Apple hereby consent to the personal jurisdiction of, and venue in, the state and federal courts within that District with respect to this License. The application of the United Nations Convention on Contracts for the International Sale of Goods is expressly excluded.

13.7 Entire Agreement; Governing Law. This License constitutes the entire agreement between the parties with respect to the subject matter hereof. This License shall be governed by the laws of the United States and the State of California, except that body of California law concerning conflicts of law.

Where You are located in the province of Quebec, Canada, the following clause applies: The parties hereby confirm that they have requested that this License and all related documents be drafted in English.

Les parties ont exigé que le présent contrat et tous les documents connexes soient rédigés en anglais.

EXHIBIT A.

"Portions Copyright © 1999-2003 Apple Computer, Inc. All Rights Reserved.

This file contains Original Code and/or Modifications of Original Code as defined in and that are subject to the Apple Public Source License Version 2.0 (the 'License'). You may not use this file except in compliance with the License. Please obtain a copy of the License at <http://www.opensource.apple.com/apsl/> and read it before using this file.

The Original Code and all software distributed under the License are distributed on an 'AS IS' basis, WITHOUT WARRANTY OF ANY KIND, EITHER EXPRESS OR IMPLIED, AND APPLE HEREBY DISCLAIMS ALL SUCH WARRANTIES, INCLUDING WITHOUT LIMITATION, ANY WARRANTIES OF MERCHANTABILITY, FITNESS FOR A PARTICULAR PURPOSE, QUIET ENJOYMENT OR NON-INFRINGEMENT. Please see the License for the specific language governing rights and limitations under the License."

#### **Info-ZIP copyright and license**

This is version 2007-Mar-4 of the Info-ZIP license. The definitive version of this document should be available at <ftp://ftp.info-zip.org/pub/infozip/license.html> indefinitely and a copy at <http://www.info-zip.org/pub/infozip/license.html>.

Copyright © 1990-2007 Info-ZIP. All rights reserved.

For the purposes of this copyright and license, "Info-ZIP" is defined as the following set of individuals:

Mark Adler, John Bush, Karl Davis, Harald Denker, Jean-Michel Dubois, Jean-loup Gailly, Hunter Goatley, Ed Gordon, Ian Gorman, Chris Herborth, Dirk Haase, Greg Hartwig, Robert Heath, Jonathan

Hudson, Paul Kienitz, David Kirschbaum, Johnny Lee, Onno van der Linden, Igor Mandrichenko, Steve P. Miller, Sergio Monesi, Keith Owens, George Petrov, Greg Roelofs, Kai Uwe Rommel, Steve Salisbury, Dave Smith, Steven M. Schweda, Christian Spieler, Cosmin Truta, Antoine Verheijen, Paul von Behren, Rich Wales, Mike White.

Permission is granted to anyone to use this software for any purpose, including commercial applications, and to alter it and redistribute it freely, subject to the above disclaimer and the following restrictions:

1. Redistributions of source code (in whole or in part) must retain the above copyright notice, definition, disclaimer, and this list of conditions.
2. Redistributions in binary form (compiled executables and libraries) must reproduce the above copyright notice, definition, disclaimer, and this list of conditions in documentation and/or other materials provided with the distribution. The sole exception to this condition is redistribution of a standard UnZipSFX binary (including SFXWiz) as part of a self-extracting archive; that is permitted without inclusion of this license, as long as the normal SFX banner has not been removed from the binary or disabled.
3. Altered versions--including, but not limited to, ports to new operating systems, existing ports with new graphical interfaces, versions with modified or added functionality, and dynamic, shared, or static library versions not from Info-ZIP--must be plainly marked as such and must not be misrepresented as being the original source or, if binaries, compiled from the original source. Such altered versions also must not be misrepresented as being Info-ZIP releases--including, but not limited to, labeling of the altered versions with the names "Info-ZIP" (or any variation thereof, including, but not limited to, different capitalizations), "Pocket UnZip," "WiZ" or "MacZip" without the explicit permission of Info-ZIP. Such altered versions are further prohibited from misrepresentative use of the Zip-Bugs or Info-ZIP e-mail addresses or the Info-ZIP URL(s), such as to imply Info-ZIP will provide support for the altered versions.
4. Info-ZIP retains the right to use the names "Info-ZIP," "Zip," "UnZip," "UnZipSFX," "WiZ," "Pocket UnZip," "Pocket Zip," and "MacZip" for its own source and binary releases.

**Parent topic:** [Notices](#)

## Trademarks

EPSON® and SureColor® are registered trademarks, and EPSON Exceed Your Vision is a registered logomark of Seiko Epson Corporation.

Apple is a trademarks of Apple Inc., registered in the U.S. and other countries.

General Notice: Other product names used herein are for identification purposes only and may be trademarks of their respective owners. Epson disclaims any and all rights in those marks.



Parent topic: [Notices](#)

## Copyright Notice

All rights reserved. No part of this publication may be reproduced, stored in a retrieval system, or transmitted in any form or by any means, electronic, mechanical, photocopying, recording, or otherwise, without the prior written permission of Seiko Epson Corporation. The information contained herein is designed only for use with this Epson product. Epson is not responsible for any use of this information as applied to other products.

Neither Seiko Epson Corporation nor its affiliates shall be liable to the purchaser of this product or third parties for damages, losses, costs, or expenses incurred by purchaser or third parties as a result of: accident, misuse, or abuse of this product or unauthorized modifications, repairs, or alterations to this product, or (excluding the U.S.) failure to strictly comply with Seiko Epson Corporation's operating and maintenance instructions.

Seiko Epson Corporation shall not be liable for any damages or problems arising from the use of any options or any consumable products other than those designated as Original Epson Products or Epson Approved Products by Seiko Epson Corporation.

Seiko Epson Corporation shall not be held liable for any damage resulting from electromagnetic interference that occurs from the use of any interface cables other than those designated as Epson approved Products by Seiko Epson Corporation.

This information is subject to change without notice.

[A Note Concerning Responsible Use of Copyrighted Materials](#)  
[Copyright Attribution](#)

Parent topic: [Notices](#)

## A Note Concerning Responsible Use of Copyrighted Materials

Epson encourages each user to be responsible and respectful of the copyright laws when using any Epson product. While some countries' laws permit limited copying or reuse of copyrighted material in

certain circumstances, those circumstances may not be as broad as some people assume. Contact your legal advisor for any questions regarding copyright law.

**Parent topic:** [Copyright Notice](#)

## **Copyright Attribution**

© 2015 Epson America, Inc.

7/15

CPD-43466

**Parent topic:** [Copyright Notice](#)